

# TELETYPE

PRINTING TELEGRAPH SYSTEMS

BULLETIN NO. 223B

DESCRIPTION AND ADJUSTMENTS  
TAPE PERFORATOR  
(DPE)

(BELL SYSTEM 15M PERFORATOR)



REG. U. S. PAT. OFF.  
CORPORATION  
SUBSIDIARY OF  
*Western Electric Company*  
CHICAGO, U. S. A.

## LIST OF EFFECTIVE PAGES

MARCH 1955

PAGE NUMBER	CHANGE IN EFFECT	PAGE NUMBER	CHANGE IN EFFECT
Title	Change 1	4-1	Original
A	Change 1	5-1 to 5-7	Original
B	Original		
C to D	Change 1		
1-1	Change 1		
2-1 to 2-2	Original		
3-1	Original		
3-2	Change 1		
3-3 to 3-5	Original		
3-6	Change 1		
3-7 to 3-9	Original		

The above list indicates the effective pages as of date of issue. When a change takes place in any of the following pages this page likewise changes,

## TABLE OF CONTENTS

Paragraph	Page	Paragraph	Page
<b>SECTION 1 - GENERAL DESCRIPTION</b>		28.	Positive Action Latch Lever
1.	General . . . . .	1-1	Spring Tension. . . . . 3-5
2.	Description of Components . . .	1-1	29. Anti-Chatter Lever Spring
a.	Keyboard. . . . .	1-1	Tension . . . . . 3-5
b.	Perforator Mechanism. . . . .	1-1	30. Punch Contact Operating Lever
c.	Tape Feed Mechanism . . . . .	1-1	Adjustable Link . . . . . 3-5
d.	Character Counter . . . . .	1-1	
3.	Auxiliaries and Accessories. . .	1-1	<b>THE FOLLOWING ADJUSTMENTS APPLY TO ALL PERFORATORS</b>
<b>SECTION 2 - THEORY OF OPERATION</b>		31.	Punch Contact Operating Lever
1.	General . . . . .	2-1	Back Stop . . . . . 3-6
2.	Keyboard. . . . .	2-1	32. Punch Contact Operating Lever
3.	Perforator Mechanism. . . . .	2-1	Return Spring . . . . . 3-6
4.	Tape Feed Mechanism . . . . .	2-1	33. Feed Pawl Eccentric. . . . . 3-6
5.	Character Counter . . . . .	2-2	34. Feed Pawl Spring Tension . . . 3-6
6.	Key Pressure Adjusting Mechanism. . . . .	2-2	35. Feed Pawl Throwout Bracket . . 3-6
<b>SECTION 3 - ADJUSTMENTS</b>		36.	Feed Pawl Guide. . . . . 3-6
1.	General . . . . .	3-1	37. Punch Magnet . . . . . 3-6
2.	Selector Bar Assembly Shims . .	3-1	38. Tape Stripper Plate. . . . . 3-6
3.	Selector Bar Assembly Bracket .	3-1	39. Tape Knife . . . . . 3-6
4.	Keylever Springs. . . . .	3-1	40. Feed Roll Detent-Final . . . . 3-7
5.	Tape Feed Roll. . . . .	3-2	41. Counter Control Contact
6.	Tape Tension Lever Stud . . . .	3-2	Operating Mechanism . . . . . 3-7
7.	Tape Tension Lever Spring . . .	3-2	42. Counter Control Contact
8.	Backspace Spring Tension. . . .	3-2	Assembly. . . . . 3-7
9.	Backspace Pawl Spring Tension .	3-2	43. Feed Pawl Bracket. . . . . 3-8
10.	Feed Roll Detent - Preliminary.	3-2	44. Ratchet Return Spring. . . . . 3-8
11.	Feed Roll Detent Spring . . . .	3-2	45. Ratchet Return Spring Tension. 3-8
12.	Selector Lever Bracket. . . . .	3-2	46. Release Magnet Armature
13.	Feed Punch Selector Lever . . .	3-3	Eccentric Stop. . . . . 3-8
14.	Armature Lever Left Stop. . . .	3-3	47. Check Latch Pawl Bracket . . . 3-8
15.	Armature Lever Right Stop . . .	3-3	48. Release Lever Extension
16.	Selector Finger Retainer. . . . .	3-3	Adjusting Screw . . . . . 3-8
17.	Tape Guide Spring . . . . .	3-3	49. Counting Magnet Armature
18.	Punch Contact Bracket . . . . .	3-3	Eccentric Stop. . . . . 3-8
<b>THE FOLLOWING ADJUSTMENTS APPLY TO UNITS NOT EQUIPPED WITH THE POSITIVE ACTION PERFORATING MECHANISM</b>		50.	Release Latch Bracket. . . . . 3-9
19.	Punch Contacts. . . . .	3-4	51. Check Latch Pawl Spring
20.	Key Pressure Adjusting Mechanism. . . . .	3-4	Tension . . . . . 3-9
21.	Anti-Chatter Mechanism. . . . .	3-4	52. Release Latch Spring Tension . 3-9
22.	Punch Contact Operating Lever Adjustable Link. . . . .	3-4	53. Dashpot. . . . . 3-9
<b>THE FOLLOWING ADJUSTMENTS APPLY TO UNITS EQUIPPED WITH THE POSITIVE ACTION MECHANISM</b>		54.	Feed Pawl Spring Tension . . . 3-9
23.	Punch Contacts. . . . .	3-4	55. Signal Lamp Contact Bracket. . 3-9
24.	Anti-Chatter Lever. . . . .	3-5	56. Signal Lamp Contact Spring . . 3-9
25.	Anti-Chatter Lever Operating Screw. . . . .	3-5	57. Signal Lamp Contact. . . . . 3-9
26.	Anti-Chatter Lever Backstop . .	3-5	58. Signal Lamp Contact Cam. . . . 3-9
27.	Position Action Latch Operating Screw. . . . .	3-5	59. Dashpot Air Vent Screw . . . . 3-9
			60. Dashpot Plunger Spring Tension 3-9
		<b>SECTION 4 - LUBRICATION</b>	
		1.	General. . . . . 4-1
		2.	Under-Part of Perforator . . . 4-1
		3.	Top of Perforator. . . . . 4-1
		4.	Counter Unit . . . . . 4-1
		<b>SECTION 5 - ILLUSTRATIONS</b>	
		1.	Bulletin 223B Illustrations (Figures 1 through 38). . . . . 5-1

CHANGE 1



223B

490829-44

C

D



223B

CHANGE 1

550225-82

## SECTION 1

## GENERAL DESCRIPTION

## 1. GENERAL

a. The Teletype Tape Perforator (DPE) is a keyboard operated device equipped only with the mechanisms necessary for the preparation of five unit code perforated tape. The perforating mechanism is actuated by an electromagnet.

b. The speed of the keyboard is not restricted to a preset rate but is dependent upon the ability of the operator. Tape can be perforated at a greater rate than can normally be used for transmission. Adjustment of the keyboard for a light or heavy finger touch is provided to suit the personal preference of each operator.

c. The perforator is furnished with a character counter which is mounted either at the left or the right of the keyboard. When the counter is located at the right of the keyboard, as on the DPE200\*\*, it is provided with an individual cover. When located at the left of the keyboard, as on the DPE201\*\*, the counter is covered by an extension of the perforator cover.

## NOTE

The double asterisk (\*\*) indicates a two-letter suffix designating the paint finish. The following finishes are now available.

AA - Black Wrinkle  
 AB - Gray Green Wrinkle  
 AC - Light Brown Wrinkle  
 AD - Dark Brown Wrinkle  
 BA - Black High Gloss

## 2. DESCRIPTION OF COMPONENTS

## a. KEYBOARD

The keyboard mechanism is mounted on the keyboard base casting. Essentially, it is composed

of a set of keylevers, selector bars, "Y" levers, and "Y" lever connecting links. Beneath the keylevers are the selector bars and a counter control contact operating mechanism.

## b. PERFORATOR MECHANISM

A bracket, which mounts the perforator mechanism, is attached to the left side of the keyboard base casting. This mechanism consists essentially of a set of punches, a punch magnet, a set of selector fingers, and "Y" lever connecting link extensions.

## c. TAPE FEED MECHANISM

The tape feed roll is located to the left of the punches. Spaced at equal intervals around the tape feed roll is a series of feed pins which engage the feed holes punched in the tape. A tape tension lever holds the tape against the tape feed roll, keeping the feed holes in constant engagement with the feed pins. The feed pawl is attached to a lever resting on the left end of the armature lever.

## d. CHARACTER COUNTER

The basic elements of the character counter are a ratchet, counter magnet, feed pawl, latch pawl, release magnet, signal lamp, operating contact springs, dial, and indicator.

## 3. AUXILIARIES AND ACCESSORIES

a. A 110 volt D.C. source is required to operate the perforating and character counting mechanisms.

b. The perforator cover, tape reel container assembly, table, and copyholder are not furnished as standard equipment with the perforator. They must be ordered separately.



## SECTION 2

## THEORY OF OPERATION

## 1. GENERAL (Figure 1)

a. A series of holes, corresponding to the code combination assigned, will be punched in the tape when a key is operated. The combinations are formed according to the pattern of the five unit code adopted for use with Teletype signal circuit equipment.

b. The character counter registers each time a character or space key is depressed and returns to the zero position when the carriage return key is depressed. Operation of the LETTERS, FIGURES, or LINE FEED keys will not cause the counter to register. The counter is provided with a signal lamp to indicate when the end of the line is being approached.

## 2. KEYBOARD (Figures 2 and 3)

The parallel selector bars are permitted only vertical motion by the guides in which they are mounted. Rectangular notches, spaced to conform to the requirements of the code, in the upper edges of each selector bar are so staggered that a high portion of one in each pair will always be in the path of a depressed keylever. Every selector bar is supported at each end by a "Y" lever. The front bar of each pair of selector bars rests on the left arms of its supporting "Y" levers and the rear bar on the right arms.

b. When a keylever is depressed, the selector bars having a high portion in line with the selected keylever will move downward. This causes the "Y" levers to lift the other bar, with a low portion in line with the selected keylever, in each pair. If the rear bar of any pair of selector bars is pushed downward, the lower extensions of the corresponding "Y" levers will be moved to the left. Similarly, they will be moved to the right if the front bar is depressed. The "Y" lever connecting links attached to the ends of the lower extensions of the "Y" levers will shift to the left when a rear selector bar is depressed, and to the right when the front selector bar is depressed.

## 3. PERFORATOR MECHANISM (Figures 3, 4, and 5)

a. The selector fingers rest in a slotted guide mounted on the armature lever just below and in line with the punches. The right end of each selector finger is attached to a selector lever that pivots at its lower end. A "Y" lever connecting link extension connects the left end of each "Y" lever connecting link to the mid-section of its corresponding selector lever. Each selector finger shifts to the left or

right as dictated by the movement of the "Y" lever connecting links.

b. The punch magnet armature is mounted on a lever. When the armature is attracted to the electromagnet core, the right end of the armature lever drops and the left end rises; lifting the left ends of the selector fingers. If a selector finger is in the extreme left, operated, position when the armature is attracted, the corresponding punch will perforate the tape. If it is in the right, unoperated, position, it will clear the corresponding punch and not perforate the tape.

c. The operation of the punch contact operating lever is similar to that of the selector levers, except a single punch contact operating bar is used. When any keylever is depressed, the punch contact operating bar moves downward, causing the "Y" lever connecting link, via the "Y" lever connecting link extension, to move the upper end of the punch contact operating lever to the left, against the tension of the retracting spring. The punch contacts mounted on the perforator bracket close and energize the punch magnet.

d. To assure positive perforation of the code combination in the tape, an anti-chatter mechanism is used. When the punch contacts are closed by depressing a keylever, the initial movement of the armature lever causes the anti-chatter lever to press the left contact point securely against the right contact point. In addition, the punch contact operating lever on the DPE200\*\* (Fig.4) is latched in the operated position. When the armature lever reaches the end of its travel, the latch screw disengages the latch, allowing the contacts to open.

## 4. TAPE FEED MECHANISM (Figure 3)

a. A tape tension lever holds the tape against the feed roll, keeping the feed holes in the tape in constant engagement with the tape feed pins.

b. As the left end of the armature rises, the feed pawl engages the next tooth on the feed roll. When the left end of the armature drops, the feed pawl will be drawn downward by its spring, causing the tape feed roll to revolve and advance the tape one space. A star wheel and detent assure equal spacing between tape perforations.

c. A backspace lever is provided for moving the tape backwards for the correction of errors. When the backspace lever is depressed, the backspace pawl engages a tooth on the star wheel and causes the feed roll to rotate clock-

wise one space. The LETTERS combination may then be perforated in place of the erroneous selection. If a character in the upper case is corrected, it will be necessary to perforate the FIGURES combination before resuming perforation of the upper case sequence.

#### 5. CHARACTER COUNTER (Figures 2, 6, and 7)

a. Closing of the punch contacts may operate the character counter in addition to energizing the punch magnet. The counter control contacts are located on the top left of the keyboard base casting. The left pair of contact points (normally closed) are the counter contacts and the right pair of contact points (normally open) are the release contacts. The left contact is connected to the counter magnets, the right contact to the release magnets, and the center contact in series with the punch operating contacts. The counter magnets will be energized, advancing the counter ratchet one tooth, each time a character or SPACE keylever is depressed.

b. Operation of the counter magnet armature causes the counter feed pawl, which is pivoted to it, to engage the next tooth on the ratchet. As the armature is released the feed pawl spring rotates the ratchet one tooth. The latch pawl then engages the ratchet and holds it in the advanced position.

c. When any function keylever, other than carriage return, is depressed, the movement of the counter control mechanism opens the left pair of counter control contacts. With both the left and right counter control contacts open, no current reaches the counter unit. The counter ratchet remains stationary.

d. When the CARRIAGE RETURN keylever is depressed, the movement of the counter control mechanism opens the left pair of counter control contacts and closes the right pair. This connects the release magnets in series with the punch contacts. The release magnet will be energized when the punch contacts close. Operation of the release magnet armature causes the release lever, which is attached to it, to disengage both the feed and latch pawls from the ratchet. The ratchet spring then returns the ratchet to its starting position. A release latch holds the release lever in the operated position and the pawls disengaged, until the start of the next counting operation. A dash pot cylinder and piston are provided to act as a buffer for the return of the ratchet.

e. A signal lamp is used in connection with the character counter to indicate when a predetermined number of characters are perforated in the tape. The signal lamp operating contacts are controlled by a contact lever which rides upon a cam attached to the ratchet shaft. The cam may be positioned on the shaft to close the lamp contacts when the desired number of combinations have been perforated in the tape.

#### 6. KEY PRESSURE ADJUSTING MECHANISM

a. The key pressure adjustment is located on the perforator mechanism. Raising or lowering the adjusting screw will vary the tension exerted by the retracting spring on the contact operating lever, and consequently the pressure required to operate the lever through the keyboard.



## SECTION 3

## ADJUSTMENTS

## 1. GENERAL

a. The following requirements and adjusting procedures for the maintenance of the Teletype Tape Perforator (DPE) are arranged in a sequence that is to be followed if a complete readjustment of the perforator is undertaken. Do not replace parts or assemblies removed to facilitate adjustment until all facilitated adjustments in that group are completed. If any adjustment is changed, all related adjustments should be checked.

b. Spring tension values noted in this bulletin are scale readings which should be obtained when Teletype scales are used as directed. Springs not meeting the requirements specified and for which no adjusting procedure is given should be replaced with new springs.

c. Before proceeding with any adjustment, carefully read the applicable portion of the text. After the adjustment is completed, be sure to tighten any screws or nuts loosened. If a part mounted on shims is to be dismantled, the number of shims used at each mounting screw should be noted. The same shim pile-up is to be replaced when remounting the part.

d. When an adjustment requires that the mechanism be electrically operated, connect the perforator to a 110 volt D.C. source.

## 2. SELECTOR BAR ASSEMBLY SHIMS (Figure 8)

## NOTE

The following adjustment is made at the factory. Readjustment is necessary only when the shim pile-up requirement has been changed or a new selector bar assembly is being installed.

a. When the B, P and Q keylevers are each in turn, fully depressed, all other keylevers should have some play between the leather up-stop and the code punch selector bars. There should be some clearance, not over .030", between the high portions of the front selector bar (A-1) and the unoperated keylevers in line with the high portions.

b. When the T keylever is fully depressed, there should be some, not over .020" clearance between the rear-most selector bar (E-2) and the unoperated keylever having the least clearance.

c. If it is necessary to change this adjustment, remove the left and right keyboard slide plates, disconnect the "Y" lever connecting links from the "Y" lever connecting link extensions, and remove the selector bar assembly.

d. Check for clearance between the left keyboard slide plate and the "Y" lever connecting links when the play is taken up to make these clearances a minimum.

## CAUTION

Exercise care in handling the unit to avoid damaging the connecting link extensions when they are disconnected from their connecting links.

e. To meet the requirements of paragraph 2.a., increase or decrease the number of shims mounted at the front corners of the selector bar assembly bracket.

f. To meet the requirements of paragraph 2.b., add or remove an equal number of shims from each of the rear corners of the selector bar assembly bracket.

g. Tighten the mounting screws. Replace the "Y" lever connecting link extensions and the keyboard slide plates.

## 3. SELECTOR BAR ASSEMBLY BRACKET (Figure 8)

The selector bar assembly bracket should be parallel to the rear keylever guide. To adjust, remove the left and right keyboard slide plates, loosen the selector bar assembly mounting screws, and position the assembly correctly. Tighten the mounting screws and replace the keyboard slide plates.

## 4. KEYLEVER SPRINGS (Figure 9)

a. To check a spring, remove it from the keyboard. Measure the spring opening as shown in the figure.

b. All character and BLANK keylever springs are made of .035" diameter wire. They should have an opening of 1-3/16".

c. CARRIAGE RETURN, LINE FEED, LETTERS, and FIGURES keylever springs are also made of .035" diameter wire. They should have an opening of 1-9/16".

d. Units equipped with a 3" space bar employ a space keylever spring made of .039" diameter wire. It should have an opening of 1-3/4".

e. Units equipped with an 8-1/2" space bar and a centrally located SPACE keylever employ a spring made of .049" diameter wire. It should have an opening of 1-5/8".

f. To adjust, bend the springs to conform to the requirements.

#### 5. TAPE FEED ROLL (Figure 10)

The tape feed roll should neither bind nor have more than .003" end play. To determine whether or not binding is occurring, lift the tape tension lever, feed pawl, and detent lever. To adjust, increase or decrease the number of shims (not shown) between the feed roll bracket and the casting. Utilize the play in the bracket mounting holes to position the bracket so the feed roll is free. Tighten the screws.

#### 6. TAPE TENSION LEVER STUD (Figure 10)

The tape tension lever stud should be centrally located with respect to the feed roll pins. This requirement should be measured as follows:

a. Take up the feed roll end play towards the star wheel and the tension lever end play towards its adjusting nut. The edge of the lever slot may touch the feed roll pins on the side of the pins nearest the ratchet but there must be clearance on the other side.

b. Take up the feed roll end play away from the star wheel and the tension lever end play away from the tension adjusting nut. The edge of the lever slot may touch the feed roll pins on the side farthest away from the ratchet but there must be clearance on the other side.

To adjust, add or remove shims between the shoulder on the tape tension lever stud and its mounting bracket.

#### 7. TAPE TENSION LEVER SPRING (Figure 11).

Hook an 32 ounce scale over the end of the tape tension lever. Pull the lever back with the spring scale perpendicular to the lever. It should require 14 to 16 ounces to start the slotted extension of the lever moving away from the feed roll. To adjust, loosen the tape tension lever stud lock nut. Rotate the stud to obtain the required tension.

#### 8. BACKSPACE SPRING TENSION (Figure 12)

It should require 4 to 6 ounces to start the backspace lever moving when the push end of an 8 ounce scale is applied vertically downward to the top of the backspace lever.

#### 9. BACKSPACE PAWL SPRING TENSION (Figure 12)

Hook an 8 ounce scale under the backspace pawl spring hole and pull vertically upward. It should require 1 to 2 ounces to start the feed pawl moving.

TO FACILITATE ADJUSTMENT OF UNITS WITH THE COUNTER MOUNTED AT THE LEFT OF THE KEYBOARD, REMOVE THE COUNTER MECHANISM.

#### NOTE

When the counter is mounted in front of the perforator, it may be removed by loosening the two screws just below the unit and sliding the unit from its mounting bracket.

#### 10. FEED ROLL DETENT - PRELIMINARY (Figure 13)

With the detent lever roller resting between two teeth of the star wheel and the armature lever held in the operated position, insert the feed roll positioning gauge (No. 73517) in the punch block guide slot so that the projection of the gauge is against the feed hole punch. Under these conditions, a pin on the feed roll should line up with the center hole of the gauge. To adjust, loosen the detent eccentric bushing mounting screw and position the bushing, keeping the center of the eccentric bushing below the center of the mounting screw. Tighten the mounting screw.

#### 11. FEED ROLL DETENT SPRING (Figure 13)

Hook a 32 ounce scale over the detent lever at the roller. Pull downward perpendicular to the lever. It should require 15 to 17 ounces to start the roller moving away from the star wheel. To adjust, hold the adjusting thumb nut and loosen the lock nut. Turn the thumb nut to obtain the proper tension. Hold the thumb nut when tightening the lock nut.

REMOVE THE TAPE STRIPPER PLATE AND THE TAPE KNIFE TO FACILITATE MAKING OR CHECKING THE FOLLOWING ADJUSTMENTS

#### 12. SELECTOR LEVER BEARING BRACKET (Figure 14)

Move the selector bars to a neutral position by simultaneously depressing the LETTERS, LINE FEED, and BLANK or the R, T, and Y keylevers

equally until stopped by the code bars. The tips of all the movable selector fingers should be under the punches by not more than half the diameter of the punches (gauged by eye). When checking this adjustment, hold the three key-levers depressed and take up the play of the selector levers in a direction to make the engagement with the punches a maximum. To adjust, loosen the selector lever bearing bracket mounting screws and position the bracket. Tighten the mounting screws.

#### 13. FEED PUNCH SELECTOR LEVER (Figure 14)

The left end of the uppermost section of the feed punch selector finger should line up with the left edge of the feed punch (gauged by eye). To adjust, position the feed punch selector lever by increasing or decreasing the number of shims between the formed-over ear and the selector lever bearing bracket.

#### 14. ARMATURE LEVER LEFT STOP (Figures 14 and 15)

With the armature lever held firmly against its left stop and the left end of the uppermost section of the feed punch selector finger in line with the left edge of the feed punch, the clearance between the feed punch selector finger and the feed punch should be .025" to .030". To adjust, position the armature lever left stop screw with its lock nut loosened.

CONNECT THE PERFORATOR TO A 110 VOLT D.C. SOURCE

#### 15. ARMATURE LEVER RIGHT STOP (Figure 14)

##### NOTE

In order to check this adjustment, it is necessary to remake it.

Position the top left edge of each punch selector finger immediately below the left edge of its associated punch. Adjust the armature lever right stop adjusting screw until the punches just fail to perforate the tape when the punch contacts are closed. Withdraw the right stop screw until all of the punches just perforate the tape when the punch contacts are closed. The punches should also completely perforate the tape when the selector fingers are positioned to the extreme left. Withdraw the right stop screw more, if necessary. To obtain margin, retract the right stop screw an additional quarter turn after the preceding requirements are met. Be certain some clearance exists between the armature and the magnet core face when the armature lever is held firmly

against its right stop screw (see paragraph 37). Tighten the lock nut.

#### 16. SELECTOR FINGER RETAINER (Figure 14)

a. There should be some clearance, not over .005", between the retainer and the top of the feed punch selector finger when the armature lever is held in its operated position by the magnet. This same clearance should exist between the retainer and each of the selector fingers when the ends are in line.

b. The retainer should be equidistant, within .005" from the No. 1 and No. 5 selector fingers when the ends of all the selector fingers are in line.

c. To adjust, loosen the retainer mounting screw and position the retainer.

DISCONNECT THE PERFORATOR FROM THE 110 VOLT D.C. SOURCE

#### 17. TAPE GUIDE SPRING (Figure 13)

a. The edge of the spring should be parallel to the edge of the casting on which it is mounted. To adjust, position the spring.

b. The spring should hold the tape securely against the side of the guide in the die block, adjacent to the No. 1 punch, without buckling the tape. Take up the play of the tape in the die block toward the spring. Observe whether or not the spring returns the tape to the far side when the tape is released. To adjust, bend the spring.

#### 18. PUNCH CONTACT BRACKET

The punch contact bracket should be positioned so that its mounting screws are in the center of the elongated holes in the bracket. Remove one mounting screw at a time in order to determine whether or not the bracket is placed properly. To adjust, loosen both mounting screws, position the bracket, and tighten the mounting screws.

##### NOTE

Before making the following adjustments, back-off the punch contact operating lever backstop screw.

THE FOLLOWING ADJUSTMENTS APPLY TO UNITS NOT EQUIPPED WITH THE POSITIVE ACTION PERFORATING MECHANISM

## 19. PUNCH CONTACTS (Figures 16 and 17)

a. With the anti-chatter lever resting against its adjusting screw, the armature lever against its left stop (Figure 14), and the right punch contact point held away from the left punch contact point by the contact operating lever, hook an 8 ounce scale over the left punch contact spring insulator. Pull perpendicular to the spring. It should require 2 to 3 ounces to separate the insulator from the anti-chatter lever (Figure 16). To adjust, bend the left punch contact spring.

b. With any keylever depressed, hook an 8 ounce scale over the right contact spring at the contact point. Pull perpendicular to the spring. It should require 2 to 3 ounces to separate the contact points (Figure 17). To adjust, bend the right punch contact spring.

## 20. KEY PRESSURE ADJUSTING MECHANISM (Figure 18)

The contact operating lever return spring adjusting mechanism should be free from binds over the entire range of the adjusting screw. The punch contact operating lever backstop screw should line up with the contact operating lever. To adjust, position the key pressure adjusting mechanism by means of its mounting screws (see Section 2, par. 6 for operating pressure adjustment).

## 21. ANTI-CHATTER MECHANISM (Figures 17 and 19)

a. With the armature lever resting firmly against its left stop and the anti-chatter lever in contact with the adjusting screw in the armature, the edge of the top-most portion of the anti-chatter contact lever should be approximately horizontal. To adjust, position the adjusting screw.

b. When adjusted in accordance with the preceding requirement, the following conditions should also exist:

(1) With the armature lever resting firmly against its right stop and the anti-chatter lever held (manually) against the magnet spool head, there should be at least .005" clearance between the anti-chatter lever and the adjusting screw (Figure 19).

(2) With the armature lever resting firmly against its left stop, the end of the anti-chatter lever should extend at least 1/32" to the left of the center of the adjusting screw. If necessary, refine the adjustment of the adjusting screw to be within the limits of both conditions, (1) and (2).

c. Unhook the anti-chatter lever spring from the bracket and hook an 8 ounce scale in the spring eye. It should require 2 to 3 ounces to stretch the spring to its position length (Figure 17).

## 22. PUNCH CONTACT OPERATING LEVER ADJUSTABLE LINK (Figure 17)

Determine the keylever (including the SPACE keylever) which moves the punch magnet contact operating lever the least amount when fully depressed. With this keylever fully depressed, there should be .015" to .030" clearance between the right contact spring and the insulator on the contact operating lever. To adjust, loosen the two screws which clamp the adjustable link together and shorten or lengthen the link. Tighten the screws.

## NOTE

With the foregoing adjustment, the punch contacts will not close until the keylevers nearly reach the bottom of their travel. It is permissible to adjust the link so the punch contacts will close on a shorter keylever stroke provided all punch selector fingers engage their associated punches by the full diameter of the pin at the time the punch contacts close. To check this adjustment, position all of the punch selector fingers to the right and then depress the LETTERS keylever slowly until the punch contacts close. Connect a lamp across the contacts to determine when they close. To adjust for a shorter keylever stroke, lengthen the punch contact operating lever link.

THE FOLLOWING ADJUSTMENTS APPLY TO UNITS EQUIPPED WITH THE POSITIVE ACTION PERFORMING MECHANISM

## 23. PUNCH CONTACTS (Figures 20 and 21)

a. The punch contact springs should be straight without sharp bends and the contact points should meet squarely in line. The left (short) punch contact spring stop should extend approximately parallel with the face of the contact bracket. Gauge by eye. To adjust, bend the spring stop.

b. With the anti-chatter lever held away from the insulator on the left contact spring, hook an 8 ounce scale over the left punch contact spring just to the rear of the contact point. Pull perpendicular to the contact spring. It should require 2 to 3 ounces to just start the left punch contact spring moving

away from the spring stop (Figure 20). To adjust, bend the left punch contact spring.

c. With any keylever depressed, clearance between the anti-chatter lever and the insulator on the left punch contact spring, and clearance between the insulator on the punch contact operating lever and the right contact spring, hook an 8 ounce scale over the right punch contact spring at the contact point. Pull perpendicular to the contact spring. It should require 3 to 4 ounces to just separate the punch contact points (Figure 21). To adjust, bend the right punch contact spring.

#### 24. ANTI-CHATTER LEVER (Figure 20)

When there is some clearance between the anti-chatter lever and the insulator on the left (short) punch contact operating spring, and the punch contact operating lever is held in the latched position by the positive action latch, there should be .002" to .004" between the punch contacts. To adjust, position the latch bracket with its mounting screws loosened.

#### 25. ANTI-CHATTER LEVER OPERATING SCREW (Figure 20)

With the armature lever resting firmly against its left (unoperated) stop and the anti-chatter lever resting firmly on the anti-chatter lever adjusting screw, there should be some clearance, not more than .005" between the anti-chatter lever and the insulator on the left (short) punch contact spring. To adjust, position the anti-chatter lever operating screw.

#### 26. ANTI-CHATTER LEVER BACKSTOP (Figure 22)

When the anti-chatter lever is resting firmly against its backstop screw, the punch contact operating lever is held in its latched position by the positive action latch, and the armature is lifted off its left stop approximately 1/16", there should be some clearance, not more than .004" between the insulator on the punch contact operating lever and the right (long) punch contact spring. To adjust, position the anti-chatter lever backstop screw in its mounting bracket.

#### 27. POSITIVE ACTION LATCH OPERATING SCREW (Figure 23)

With the punch contacts closed and the punch contact operating lever held so the latch extension on the lever is in line with the low surface of the latching tip on the latch, there should be some clearance, not over .005" between the latch and the latch extension on the

punch contact operating lever. To adjust, position the positive action latch operating screw.

#### 28. POSITIVE ACTION LATCH LEVER SPRING TENSION (Figure 24)

When the punch contact operating lever is resting against its backstop screw, and the positive action latch lever is resting against the latch extension on the lever, hook an 8 ounce scale over the tip of the latch. Pull parallel to the latch spring. It should require 1/2 to 1-1/2 ounces to just start the latch moving away from the latch extension.

#### 29. ANTI-CHATTER LEVER SPRING TENSION (Figure 20)

When the armature lever is resting firmly against its left stop and the anti-chatter lever adjusting screw is adjusted, hook a 32 ounce scale under the anti-chatter lever. Pull in line with the spring. It should require 11 to 14 ounces to just start the anti-chatter lever moving away from the anti-chatter lever adjusting screw.

#### 30. PUNCH CONTACT OPERATING LEVER ADJUSTABLE LINK (Figure 21)

a. For early closure and shallow touch, the punch contact points should close when all punch selector fingers just cover the full face of the punch pins. Move the punch selector fingers slowly under the punches from their extreme right (spacing) position by slowly depressing the LETTERS keylever. To adjust, shorten or lengthen the two-part adjustable link by means of its elongated holes and clamping screws.

b. For late closure and deep touch, the punch contact points should close so that there is not less than .015" clearance between the insulator on the punch contact operating lever and the right (long) punch contact spring when any keylever is fully depressed until blocked by the first pair (A1 and A2) of selector bars. There should be some clearance between the insulator on the left (short) punch contact spring and the anti-chatter lever. Try all keylevers; including the SPACE bar keylever. To adjust, shorten or lengthen the two-part adjustable link by means of the elongated holes and clamping screws.

CONNECT THE PERFORATOR TO A 110 VOLT D;C. SOURCE

THE FOLLOWING ADJUSTMENTS APPLY TO ALL PERFORATORS

### 31. PUNCH CONTACT OPERATING LEVER BACKSTOP (Figures 19 and 25)

Depress and then slowly release any keylever until the punch contact points are just separated by the contact operating lever as it is pulled toward the right by the contact operating lever retracting spring. With the keylever held in this position, there should be .010" to .020" between the contact operating lever backstop and the right edge of the contact operating lever. To adjust, loosen the backstop screw lock nut and position the screw. Tighten the lock nut.

DISCONNECT THE PERFORATOR FROM THE 110 VOLT D.C. SOURCE

### 32. PUNCH CONTACT OPERATING LEVER RETURN SPRING (Figure 18)

In making this measurement, the right punch contact spring should be allowed to bear freely against the fiber on the contact operating lever. Apply the push end of an 8 ounce scale to the right punch contact spring at the contact point. Push in a horizontal direction. It should require 1/2 to 1 ounce to just start the contact operating lever moving away from the backstop screw. To adjust, advance the spring adjusting screw (key pressure adjusting screw) to its highest portion. Then, position the extension on the adjusting lever by means of the elongated slot in the extension to meet the requirement.

### 33. FEED PAWL ECCENTRIC (Figure 14)

The feed pawl should engage a tooth on the feed roll without over-travel when the feed punch selector finger just touches the feed punch. To adjust, loosen the feed pawl eccentric bushing mounting screw and position the bushing to obtain the proper setting. Tighten the bushing mounting screw.

### 34. FEED PAWL SPRING TENSION (Figure 14)

Unhook the lower end of the feed pawl spring from its post and attach a 12 pound scale. Pull downward. It should require 3 to 4 pounds to stretch the spring to installed length.

### 35. FEED PAWL THROWOUT BRACKET (Figure 14)

With the armature lever resting against its left stop, there should be .005" to .015" clearance between the tip of the tooth on the feed pawl and the tips of the teeth on the feed roll throughout one complete revolution of the feed roll. To adjust, loosen the feed pawl throwout

bracket mounting screw and adjusting screw lock nut. Secure them friction tight. With the adjusting screw in contact with the punch block, advance or withdraw the screw until the desired clearance is obtained. Tighten the lock nut and the mounting screw.

CONNECT THE PERFORATOR TO A 110 VOLT D.C. SOURCE

### 36. FEED PAWL GUIDE (Figure 26)

Close the punch contacts. When the feed roll is rotated, there should be some clearance, not more than .005" between the feed pawl and the closest feed roll tooth. To adjust, position the feed pawl guide by means of its two mounting screws.

### 37. PUNCH MAGNET (Figure 27)

Close the punch contacts. With the armature lever resting against its right stop, there should be .004" to .008" clearance between the magnet cores and the armature lever. Adjustment is facilitated by removing the chad chute cover plate on units with the counter mounted to the right of the keyboard or the counter mounting bracket on units with the counter mounted to the left of the keyboard. To adjust, loosen the two eccentric stop mounting screws. Rotate the eccentrics away from the core. Loosen the magnet core mounting screws and position the core. Tighten the mounting screws. Rotate the eccentrics so they make contact with the core and tighten the eccentric mounting screws. Replace the parts removed to make this adjustment.

REPLACE THE TAPE STRIPPER PLATE AND TAPE KNIFE

### 38. TAPE STRIPPER PLATE (Figure 28)

There should be some clearance, not over .010" between the tape stripper plate and the feed roll throughout one complete revolution of the feed roll. To adjust, loosen the mounting screws and position to plate. Tighten the mounting screws.

### 39. TAPE KNIFE (Figure 28)

The tape knife should be approximately horizontal. There should be a minimum of .015" clearance between the tape knife and the tape stripper at their closest point. To adjust, loosen the tape knife mounting screws and position the knife. Tighten the mounting screws.



## 40. FEED ROLL DETENT - FINAL (Figure 13)

The feed hole perforations in the tape should conform to the standard spacing of 10 holes to the inch. Check the tape against the tape gauge (No. 2215). To adjust, loosen the detent lever eccentric bushing mounting screw and position the bushing, using the lower semi-circle of its adjusting range. Tighten the mounting screw.

## NOTE

If it is found necessary to refine this adjustment, recheck the FEED PAWL ECCENTRIC and the FEED PAWL THROWOUT BRACKET adjustments.

DISCONNECT THE PERFORATOR FROM THE 110 VOLT D.C. SOURCE

## 41. COUNTER CONTROL CONTACT OPERATING MECHANISM (Figure 29)

a. With the FIGURES keylever and any two other keylevers depressed until stopped by the selector bars, the cam levers should be just completely displaced. There should be little or no further displacement of the counter control contact operating fiber extension as the FIGURES keylever is depressed to its full depth of stroke. Repeat this procedure using the CARRIAGE RETURN keylever instead of the FIGURES keylever.

It is important that the full displacement of the cam lever is not reached until the function keylever just reaches its neutral position. Adjust by means of shims located between the counter contact operating mechanism casting and the bracket.

b. With the cam lever links against their backstops, the unoperated position, there should be approximately equal clearance between the CARRIAGE RETURN and LINE FEED keylevers and the tips of their respective cam levers. To adjust, position the counter control contact operating mechanism laterally by means of the elongated holes.

## 42. COUNTER CONTROL CONTACT ASSEMBLY (Figure 30)

## NOTE

Remove the contact cover by loosening its mounting nuts. The contact springs are numbered from left to right with contact spring No. 3 nearest to the resistor. In measuring the spring tensions, apply an 8

ounce scale to the contact spring at the contact point and pull or push perpendicular to the spring.

a. Counter contact springs No. 1 and No. 2 should be approximately perpendicular to the insulator pile-up in the assembly. Each counter contact point should have a follow of .005" to .010" when the mating spring is moved away. Adjust by bending the spring stops for contact springs No. 1 and No. 2.

b. It should require 1 to 1-1/2 ounces, applied first to spring No. 1, then to No. 2, to just separate the contact points on contact springs No. 1 and No. 2. To adjust, bend contact spring No. 1 or No. 2. Recheck requirement "a" above.

c. The contact operating fiber extensions of the counter control contact mechanism should move freely in their guide slots. When the rear contact operating fiber extension is held to the right against the backstop, there should be not over .005" clearance between contact spring No. 2 and the right edge of the fiber tip. To adjust, position the counter control contact assembly by means of the elongated bracket-mounting holes.

d. Contact spring No. 3 should be held by its backstop so that when the CARRIAGE RETURN keylever is depressed slowly, contact spring No. 3 will be moved .005" to .010" by the action of the contact point on contact spring No. 2. To adjust, bend the spring stop for contact spring No. 3.

e. With the CARRIAGE RETURN keylever fully depressed, it should require 3/4 to 1 ounce applied to contact spring No. 3 to just separate the contact points on contact springs No. 2 and No. 3. To adjust, bend the No. 3 contact spring. Recheck requirement "d" above.

f. With the contact operating fiber extensions on the counter contact operating mechanism not touching contact springs No. 1 and No. 2, there should be at least .015" clearance between the contact points on contact springs No. 2 and No. 3. If this clearance does not exist, it is necessary to refine the preceding adjustments to obtain the required clearance.

g. When the CARRIAGE RETURN keylever is depressed, contact spring No. 2 should move toward the right and break contact with the contact point on contact spring No. 1 before it makes contact with the contact point on contact spring No. 3. If adjustment is necessary, refine the preceding adjustments to meet the "break" before "make" requirement.

h. Replace the contact cover. Hold the mounting screws with a screw driver when tightening the nuts to avoid loosening the contact pile-up mounting screws.

CHARACTER COUNTER ADJUSTMENTS. THESE ADJUSTMENTS ARE MADE FROM THE REAR AND ALL INSTRUCTIONS ASSUME THIS POINT OF VIEW.

NOTE

If the counter unit is mounted at the right, remove the counter unit cover mounting screws from the under side of the mounting plate and remove the cover. Place the counter unit face down, to one side of the keyboard, without disconnecting the wires.

43. FEED PAWL BRACKET (Figure 31)

With the counting magnet armature play taken up in an outward direction, the outer edge of the pawl should not extend more than .035" outside the outer surface of the ratchet. With the play taken up in the opposite direction, the outer surface of the pawl should not be more than .015" within the outer surface of the ratchet. To adjust, remove the armature assembly from the unit. Set the screws which hold the bracket to the armature so that the bracket is friction tight, and replace the armature assembly on the unit. Adjust the bracket for the correct position of the pawl, remove the armature assembly, and tighten the bracket mounting screw. Replace the armature assembly.

44. RATCHET RETURN SPRING (Figure 31)

The ratchet should be free throughout one complete revolution in a counterclockwise direction. To adjust, remove the dashpot, taking care to permit the ratchet spring to unwind slowly to prevent breakage of the spring. Wind the ratchet spring by turning the ratchet in a counterclockwise direction until the spring is tight. Rotate the ratchet in a clockwise direction less than two but more than one complete revolution. Position the ratchet so the stop lug is approximately in the center of the lower left hand quadrant. Engage the latch pawl to hold the ratchet in place. Replace the dashpot and position it so the stop lug is in full engagement with the plunger throughout the plunger stroke.

45. RATCHET RETURN SPRING TENSION (Figure 31)

Manually operate the release magnet armature and hold the dashpot plunger depressed. Hook an 8 ounce scale over the ratchet spoke with the stop lug at the point on the spoke nearest

the periphery of the ratchet. Pull in a counterclockwise direction perpendicular to the radius. It should require 1-1/2 to 3 ounces to move the stop lug away from the end of the plunger.

46. RELEASE MAGNET ARMATURE ECCENTRIC STOP (Figure 32)

With the feed pawl in full engagement with the teeth on the ratchet, there should be .010" to .020" clearance between the release lever extension and the feed pawl when the release magnet armature is against its eccentric stop screw. To adjust, loosen the eccentric stop mounting screw and position the eccentric. Tighten the mounting screw.

47. CHECK LATCH PAWL BRACKET (Figure 33)

NOTE

When making this adjustment, back off the release lever extension adjusting screw, and hold the check latch pawl in full engagement with a tooth on the ratchet.

With the counting magnet armature against the magnet cores, the teeth on the feed pawl should over-travel the ratchet teeth .008" to .020". To adjust, loosen the check latch pawl bracket mounting screws and position the bracket. Tighten the mounting screws.

48. RELEASE LEVER EXTENSION ADJUSTING SCREW (Figure 31)

Manually position the release magnet armature against the magnet cores. Hold the ratchet so the teeth on the check latch pawl are not opposite the place on the ratchet where there are no teeth. There should be .015" to .025" clearance between the check latch pawl and the ratchet. To adjust, loosen the release lever extension adjustment screw lock nut and position the screw. Tighten the lock nut.

49. COUNTING MAGNET ARMATURE ECCENTRIC STOP (Figure 34)

When the counting magnet armature is operated, its feed pawl should rotate the ratchet one tooth and the check latch pawl should be in full engagement with a tooth on the ratchet, with slight over-travel not over .010", when the counting magnet armature is against its eccentric stop. Check this over-travel throughout a complete revolution of the ratchet. To adjust, loosen the eccentric stop mounting screw and position the eccentric. Tighten the mounting screw.

## 50. RELEASE LATCH BRACKET (Figure 35)

When the release magnet armature manually held against the magnet cores, the release lever extension should over-travel the notch in the release latch .004" to .015". To adjust, loosen the release latch bracket mounting screws and position the release latch bracket. Tighten the screws.

## 51. CHECK LATCH PAWL SPRING TENSION (Figure 31)

With the release magnet armature held against the magnet cores, hook an 8 ounce scale in the spring hole of the check latch pawl. Pull in line with the spring. It should require 1-1/2 to 2-1/2 ounces to start the pawl moving.

## 52. RELEASE LATCH SPRING TENSION (Figure 33)

With the release latch in its unlatched position, hook an 8 ounce scale in the notch on the release latch. Pull in such a direction that the scale passes over the spring post. It should require 3/4 to 1-3/4 ounces to start the latch moving.

## 53. DASHPOT (Figure 31)

With the plunger pushed into the dashpot cylinder the maximum amount, the stop lug on the ratchet resting firmly against the end of the plunger, and the check latch pawl in engagement with the ratchet, there should be some, not over .004" clearance between the engaging faces of the first tooth on the ratchet and the first (outer) tooth on the check latch pawl. Under the preceding conditions, the indicator should point to zero on the dial. Also, the point of contact of the plunger against the ratchet stop lug should be at least .040" from the edge of the stop lug throughout the travel of the plunger. To adjust the dashpot, loosen the dashpot mounting screws and position the dashpot. Tighten the mounting screws. Loosen the indicator set screws and position the indicator. Locate it so the outer edge of the hub is flush with the end of the shaft.

## 54. FEED PAWL SPRING TENSION (Figure 31)

Hold the release magnet armature against the magnet cores and hook an 8 ounce scale over the feed pawl bearing screw. Pull as nearly parallel as possible to the feed pawl. It should require 5 to 7 ounces to start the pawl moving.

## 55. SIGNAL LAMP CONTACT BRACKET (Figure 36)

With the lamp contact lever on the low part of the lamp contact cam, there should be some

clearance, not over .015" between the lamp contact lever and the insulator. To adjust, loosen the contact bracket mounting screws and position the bracket. Tighten the screws.

## 56. SIGNAL LAMP CONTACT SPRING (Figure 36)

With the lamp contact operating lever on the low part of the cam, there should be .010" to .015" clearance between the lamp contact points. To adjust, bend the short lamp contact spring stop. The contact spring should make contact with the stiffener (stop) throughout its length.

## 57. SIGNAL LAMP CONTACT (Figure 37)

With the lamp contact lever on the high part of the cam, hook an 8 ounce scale over the short lamp contact spring between the contact and the stop. Pull perpendicular to the spring. It should require 2 to 3 ounces to separate the contacts. To adjust, bend the short lamp contact spring.

## 58. SIGNAL LAMP CONTACT CAM (Figures 31 and 37 for location of parts)

Rotate the ratchet to the first space (scale indicates zero). Operate the release magnet armature and then the counting magnet armature sixty-four times. The lamp contacts should close on the sixty-fifth operation. To adjust, loosen the lamp contact cam set screw and position the cam, simultaneously locating it so the ratchet shaft has some end play, not over .004". Tighten the set screw.

## 59. DASHPOT AIR VENT SCREW (Figure 7)

When the dashpot air vent is properly adjusted, the ratchet should return from its farthest position to its zero position without bouncing. When it is returned from the eighth space, it should return quickly enough to prevent feeding of more than one tooth when a character key-lever is depressed immediately after the ratchet has been released. To adjust, loosen the dashpot air vent screw lock nut and position the air vent screw. Tighten the lock nut.

## 60. DASHPOT PLUNGER SPRING TENSION

With the dashpot held in a vertical position and the ratchet rotated clockwise so as to move the ratchet stop arm away from the plunger, apply an 8 ounce scale to the end of the plunger. Push upward. It should require 1/2 to 1 ounce to move the plunger all the way.

REPLACE THE CHARACTER COUNTER UNIT

## SECTION 4

## LUBRICATION

## 1. GENERAL

Proper attention to lubrication will assure trouble-free service. Use the lubricants listed in the supplement furnished with this bulletin. Unless otherwise specified, one or two drops of oil at each of the places listed will be sufficient.

Apply oil to both loops of all helical springs that exert a nominal tension of less than 2-1/2 pounds. Apply grease to both loops of all other helical springs.

## 2. UNDER-PART OF PERFORATOR

a. KEYLEVERS - Keylever shaft and rear comb slots.

b. SELECTOR BAR GUIDE SLOTS.

c. "Y" LEVERS - bearing slots and arms.

d. "Y" LEVER CONNECTING LINKS - connections with extensions and "Y" levers.

e. SELECTOR LEVERS.

f. COUNTER CONTROL CAM LEVERS - At pivot points and points of engagement with keylevers.

## 3. TOP OF PERFORATOR

a. KEYLEVER FRONT COMB SLOTS

b. "Y" LEVER CONNECTING LINK EXTENSIONS - left end connections.

c. SELECTOR FINGERS - At selector lever connections, guide slots, and at points of engagement with punches and armature lever.

d. ARMATURE LEVER - two oil holes.

e. SELECTOR LEVER RETAINER.

f. ANTI-CHATTER CONTACT LEVER - pivot and point of engagement.

g. ANTI-CHATTER LEVER LATCH (if unit is so provided) - at bearing and at point of engage-

ment with latch screw and punch contact operating lever.

h. PUNCH CONTACT OPERATING LEVER BACKSTOP BRACKET SLOT (in units with slotted backstop bracket).

i. PUNCH BLOCK - rear oil hole, punches, guide pins.

j. FEED ROLL - bearings, ratchet teeth, star wheel.

k. TAPE TENSION LEVER BEARINGS.

l. BACK SPACE LEVER - Shoulder screw bearings.

m. BACK SPACE PAWL BEARING SCREW.

n. FEED PAWL - bearing screw.

o. FEED PAWL LEVER - at pivot.

## 4. COUNTER UNIT

## NOTE

Care should be exercised to prevent oil from getting between the pole faces of the magnets and the armature.

a. COUNTER AND RELEASE MAGNET ARMATURE BEARINGS.

b. FEED PAWL BEARING SCREW.

c. CHECK LATCH PAWL - bearing screw and at point of engagement with adjusting screw.

d. LATCH PAWL - bearing screw and on latching surface.

e. RATCHET WHEEL - on teeth, outer bearings, and in drum.

f. CONTACT LEVER BEARING AND CAM.

g. DASHPOT PLUNGER.



COUNTER CONTROL CONTACT ASSEMBLY

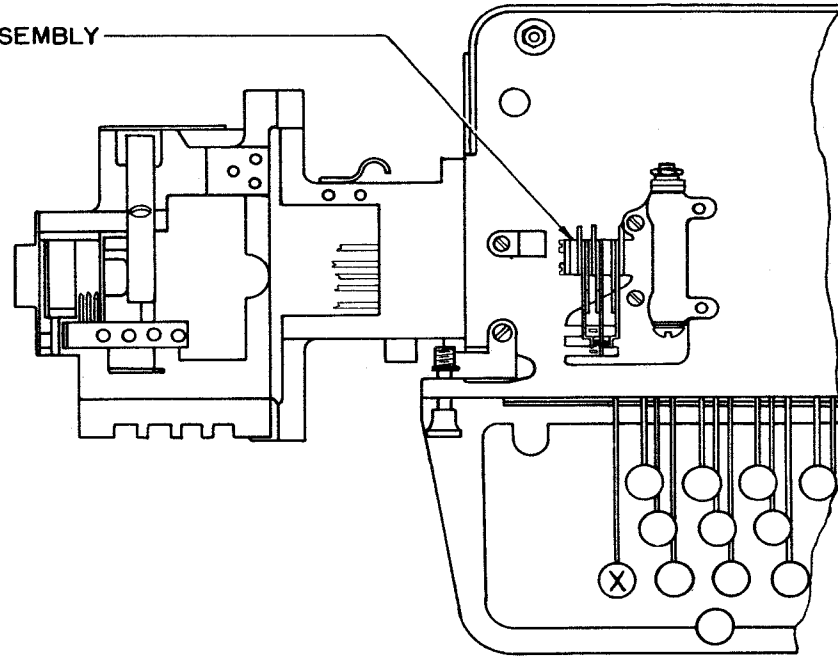

FIGURE 6

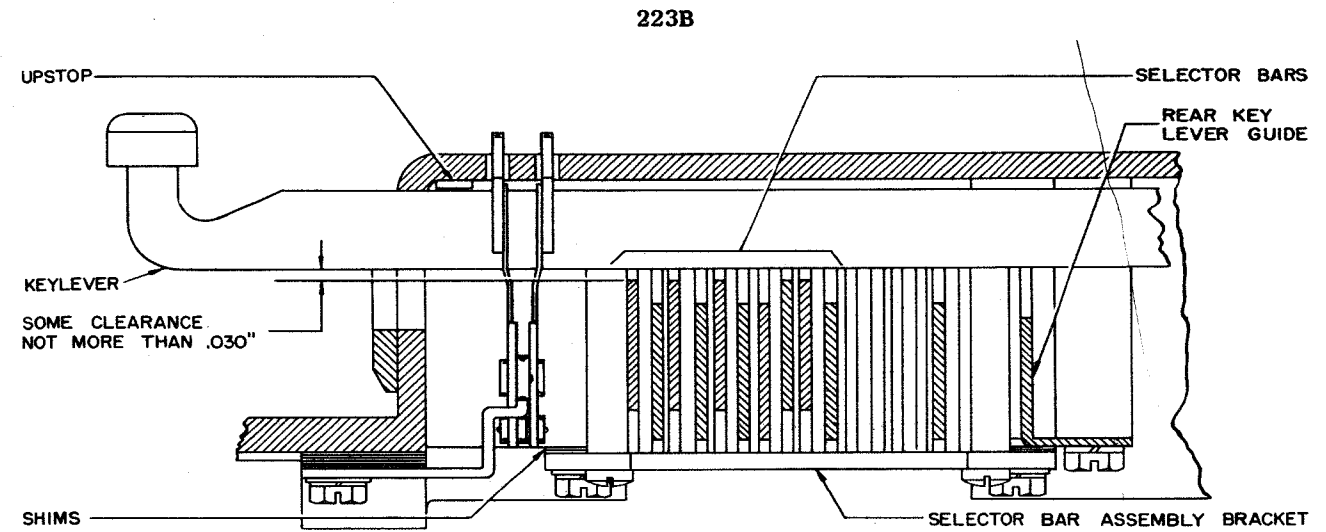

FIGURE 8

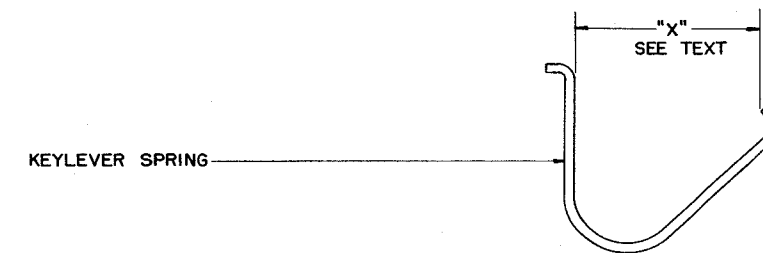

FIGURE 9

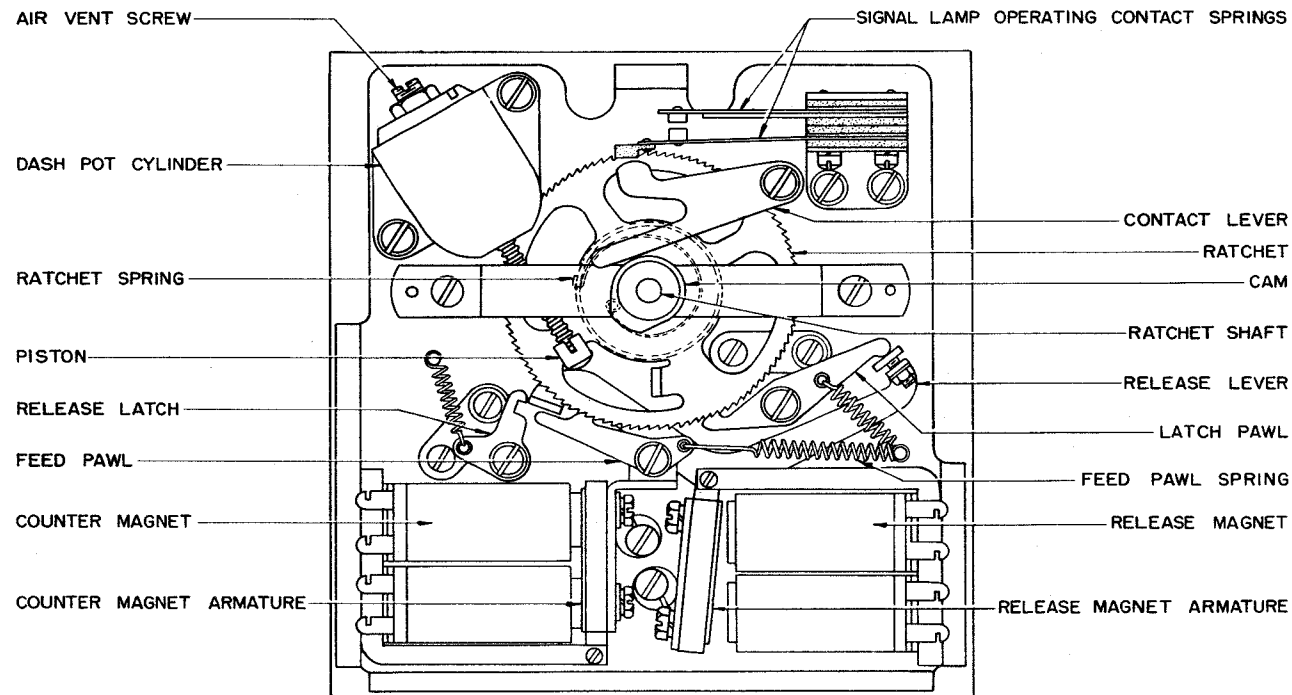

FIGURE 7

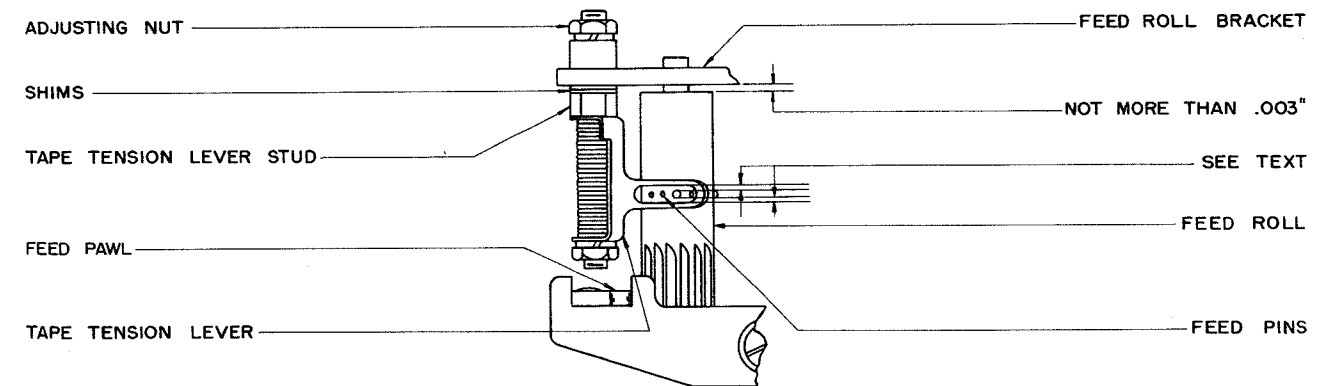

FIGURE 10



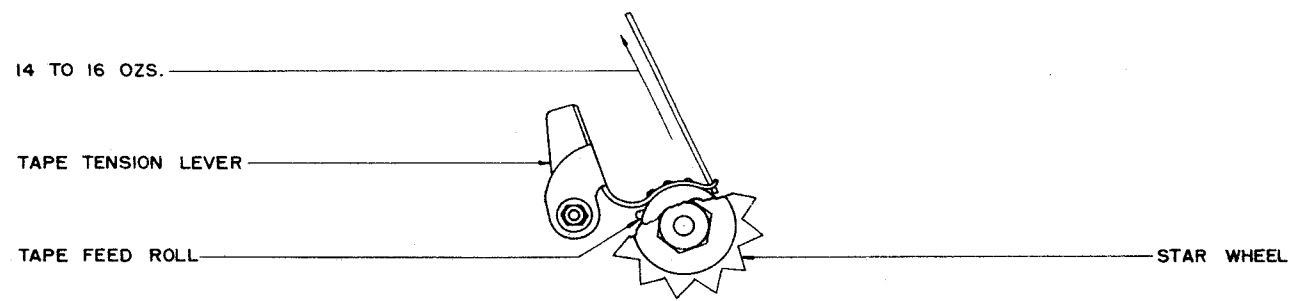

FIGURE 11

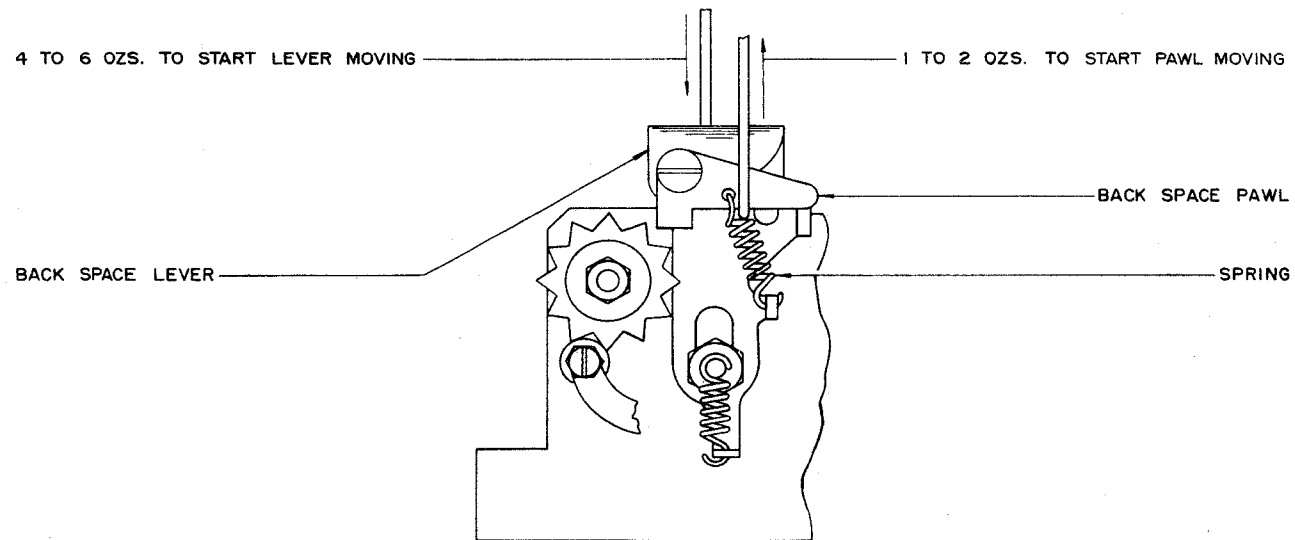

FIGURE 12

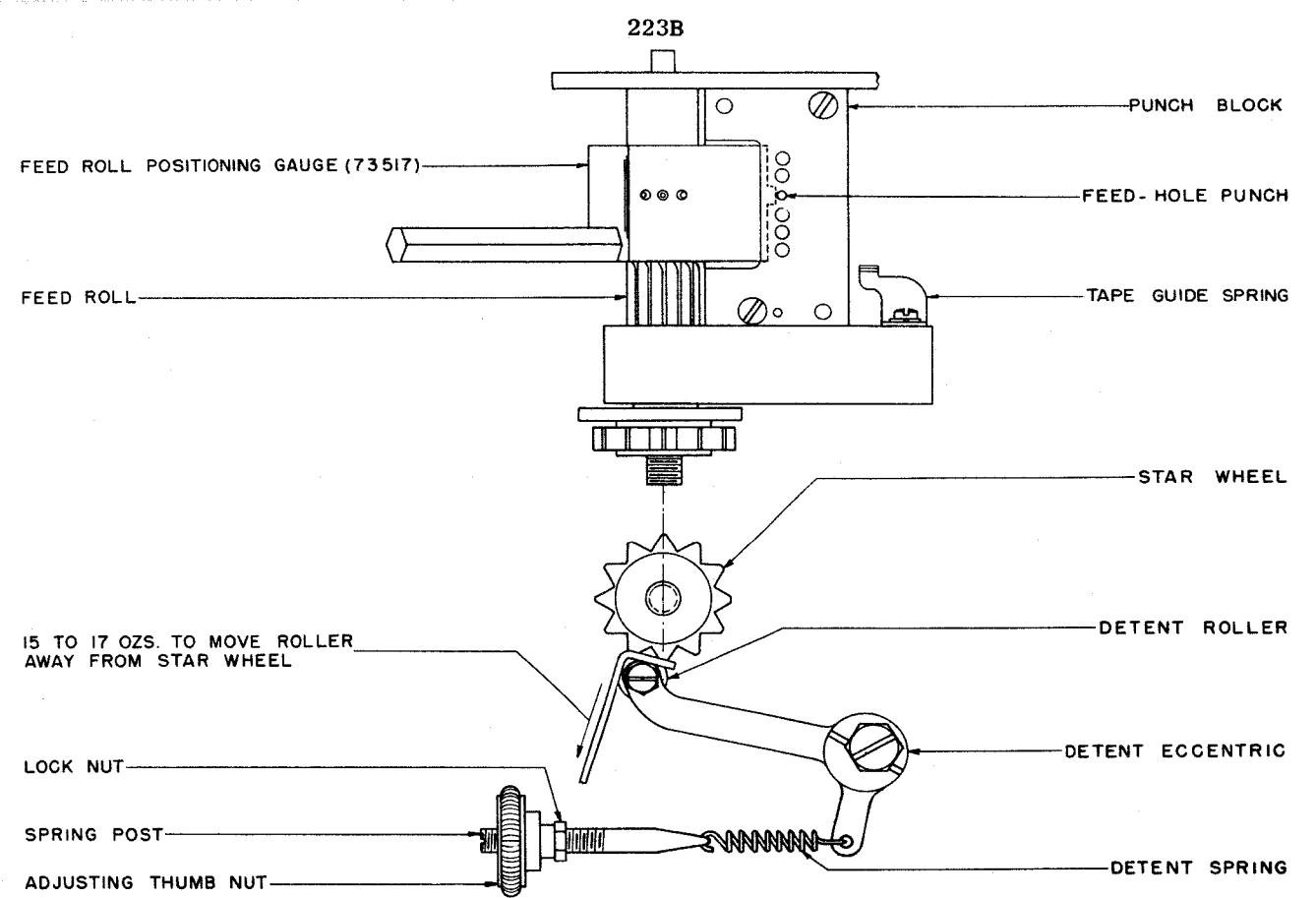

FIGURE 13

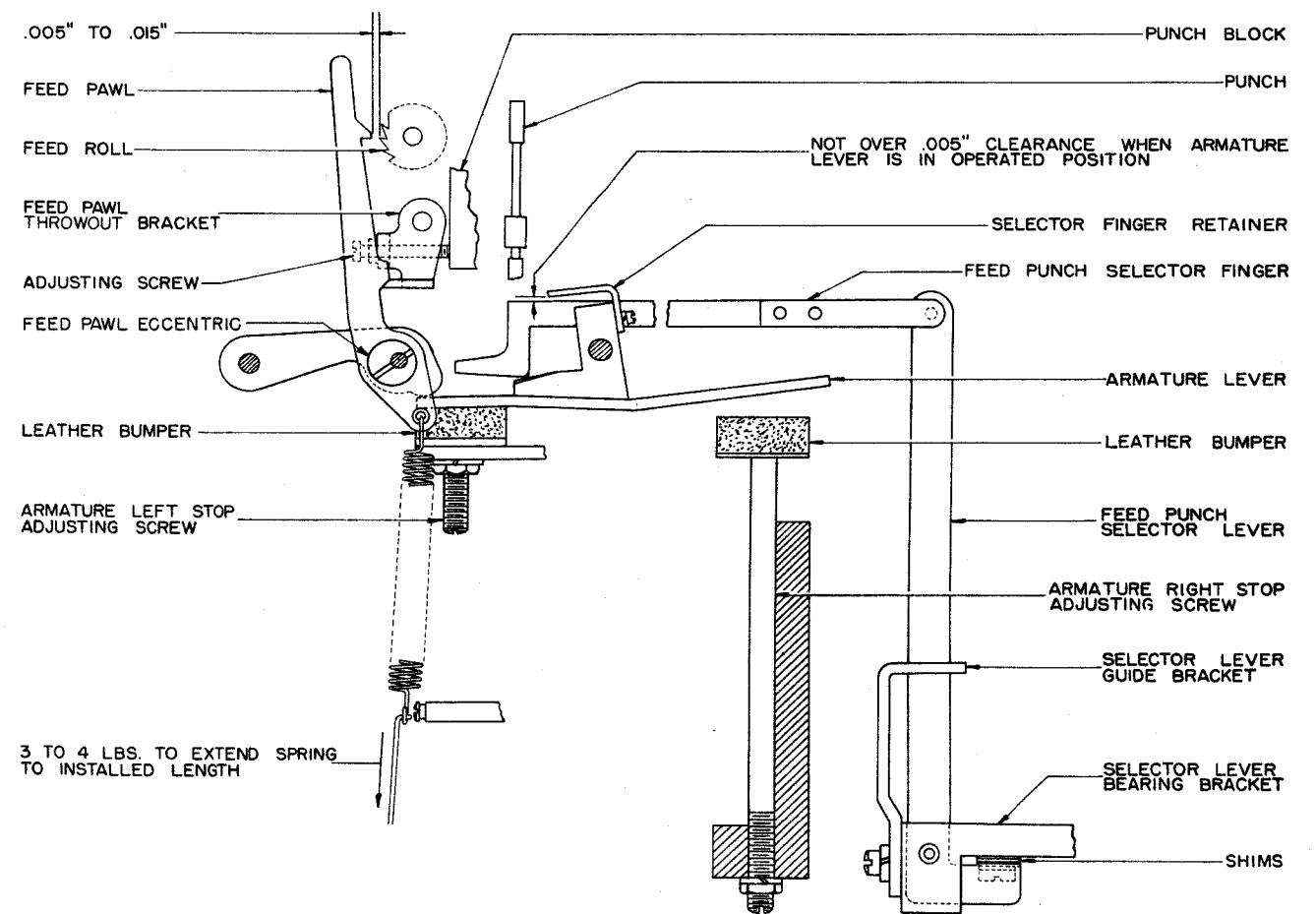

FIGURE 14

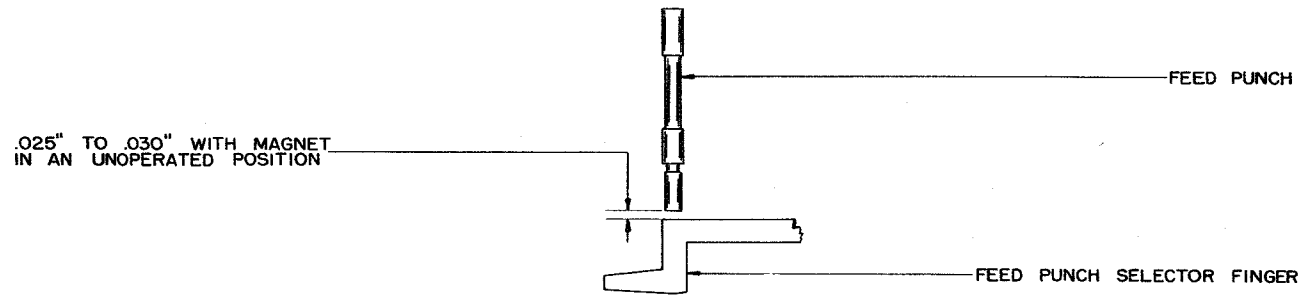

FIGURE 15

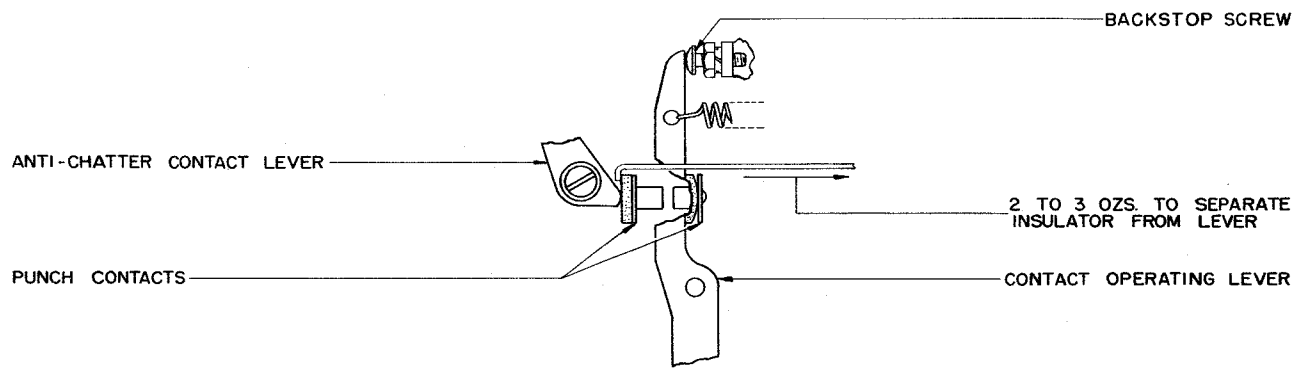

FIGURE 16

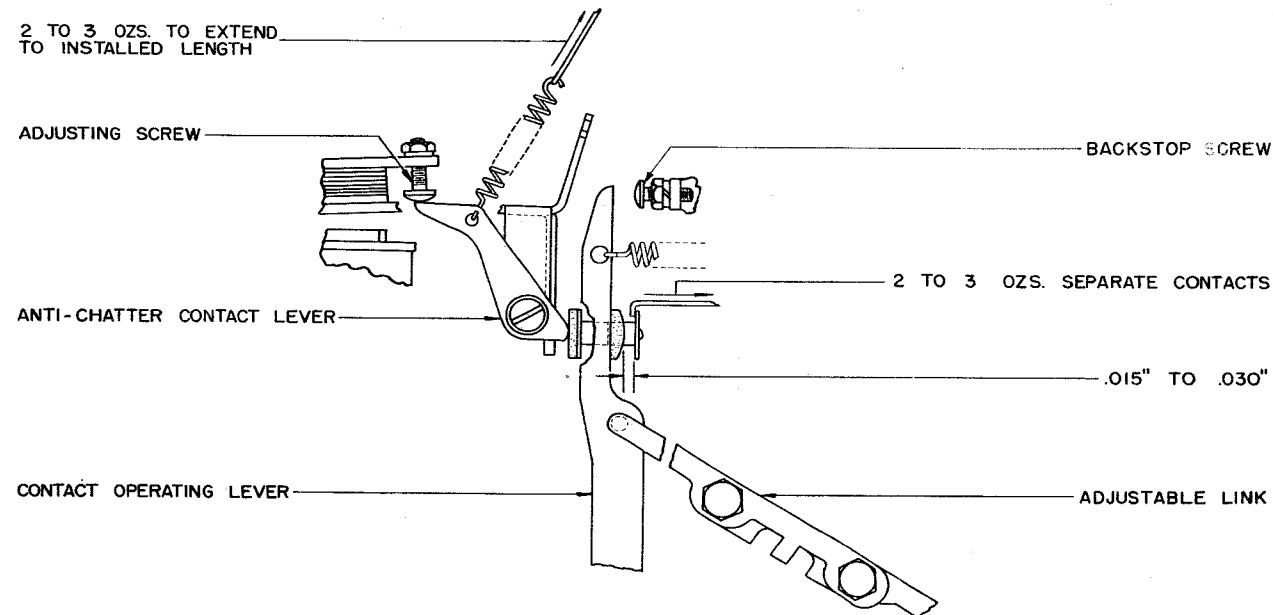

FIGURE 17

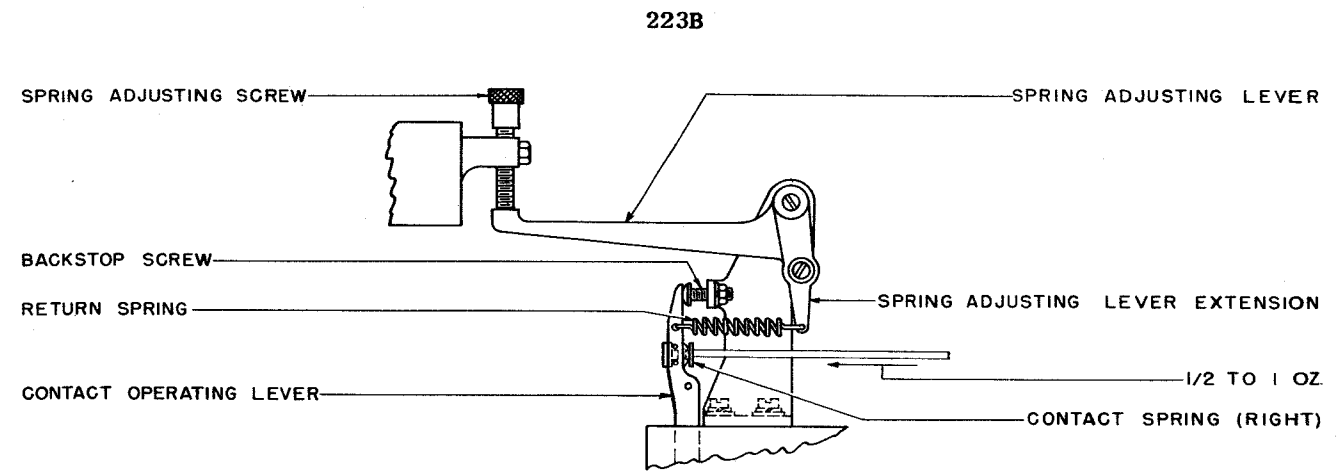

FIGURE 18

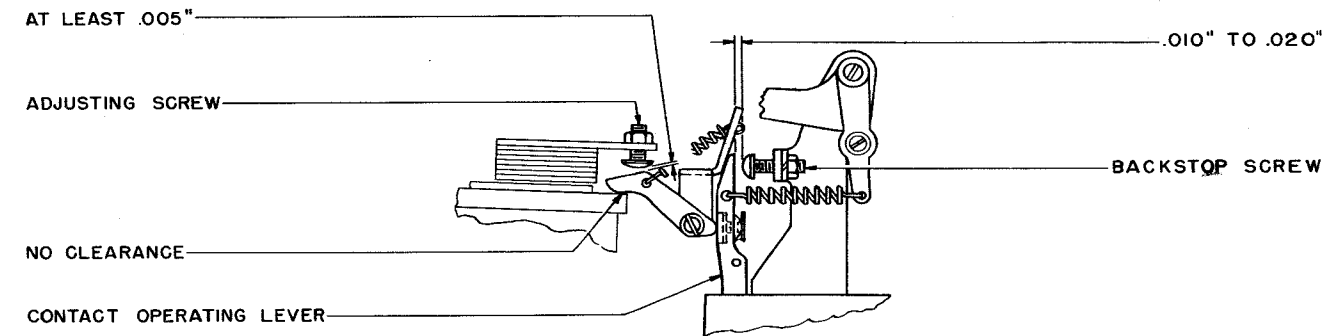

FIGURE 19

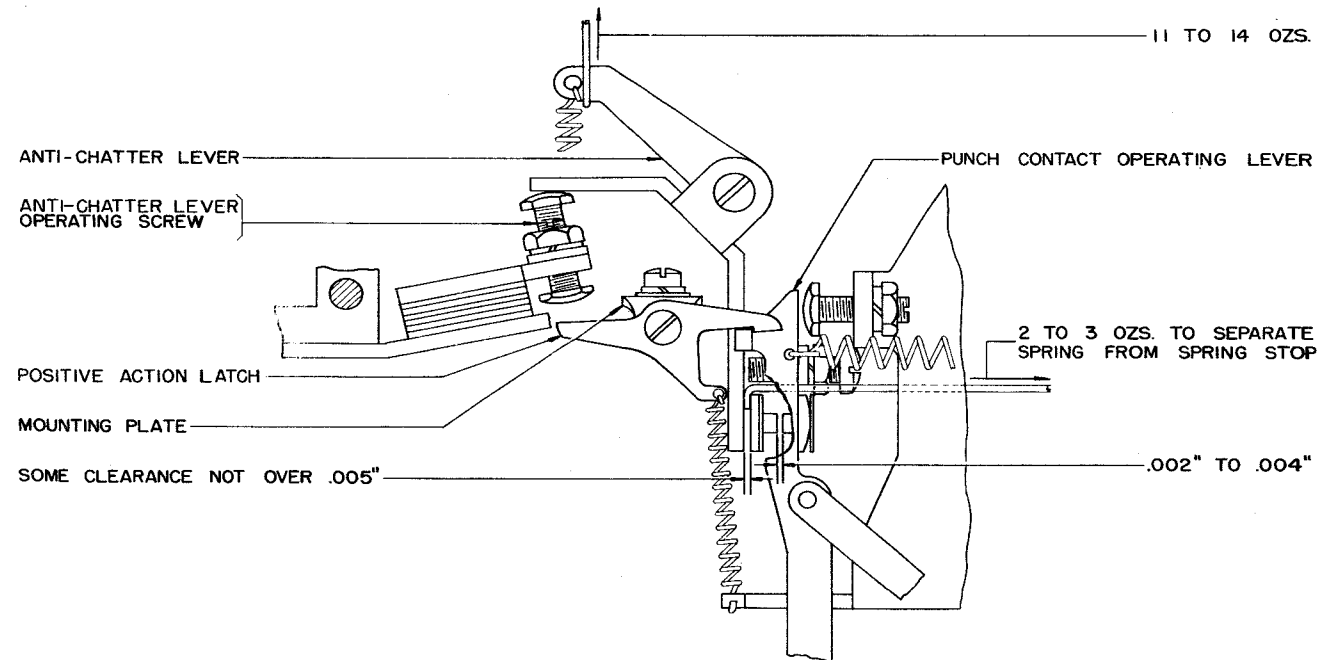

FIGURE 20

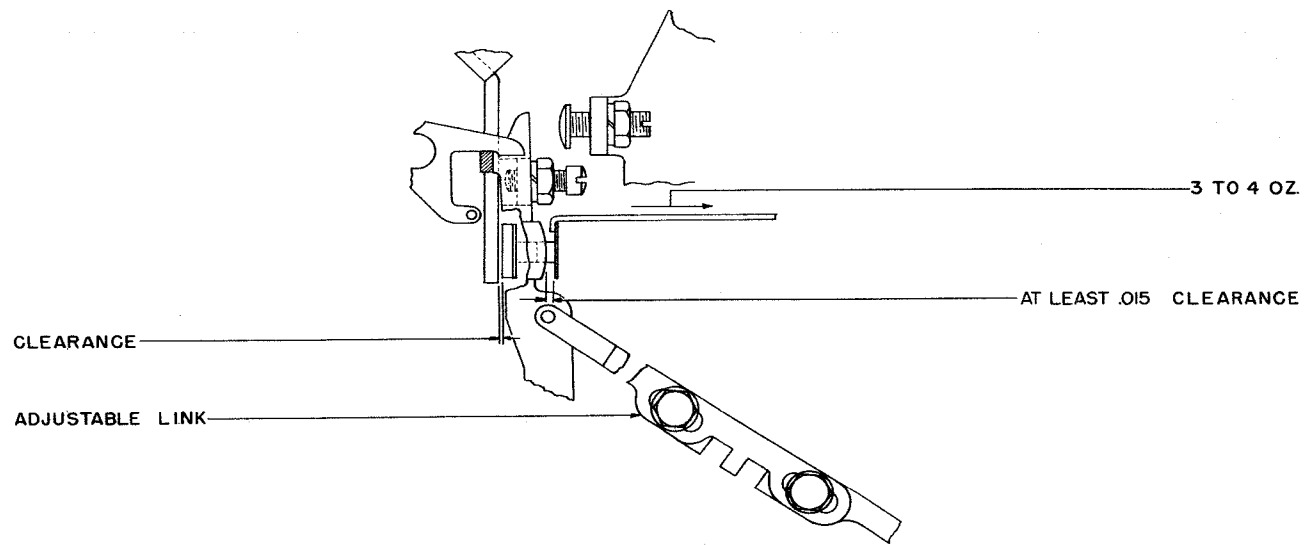

FIGURE 21

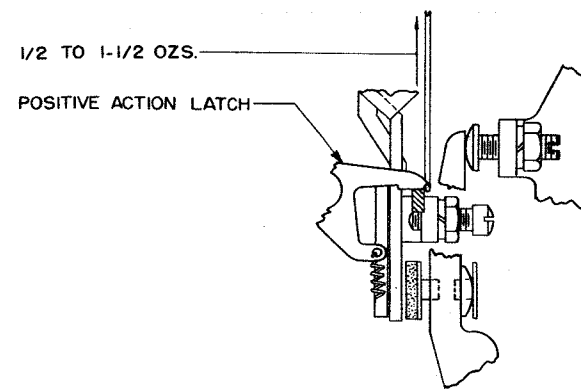

FIGURE 24

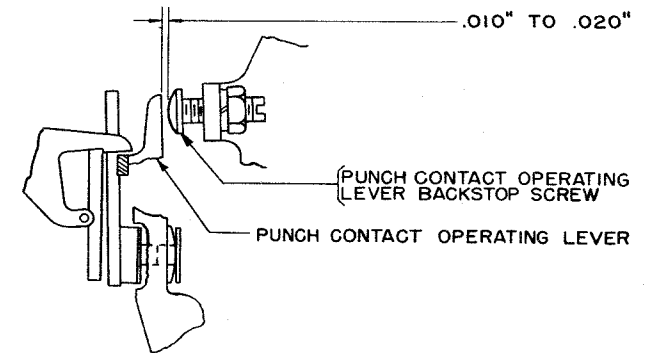

FIGURE 25

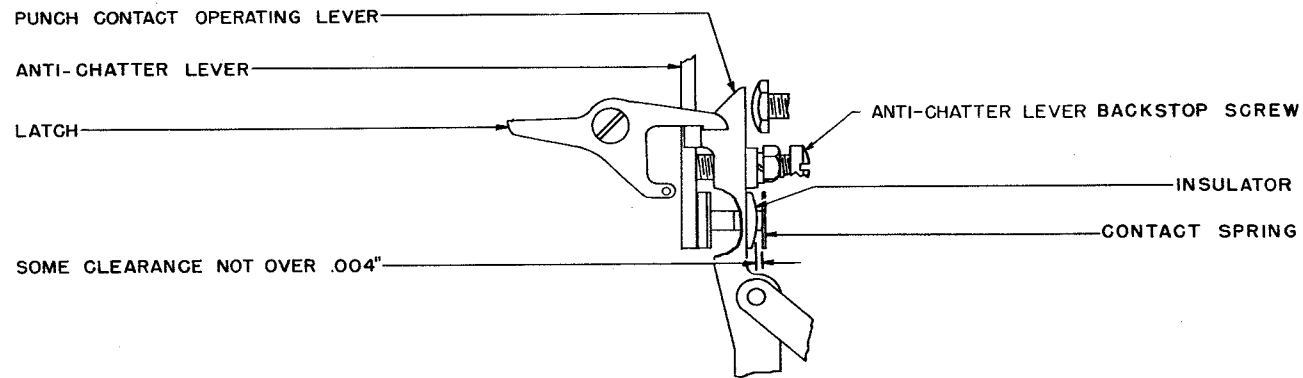

FIGURE 22

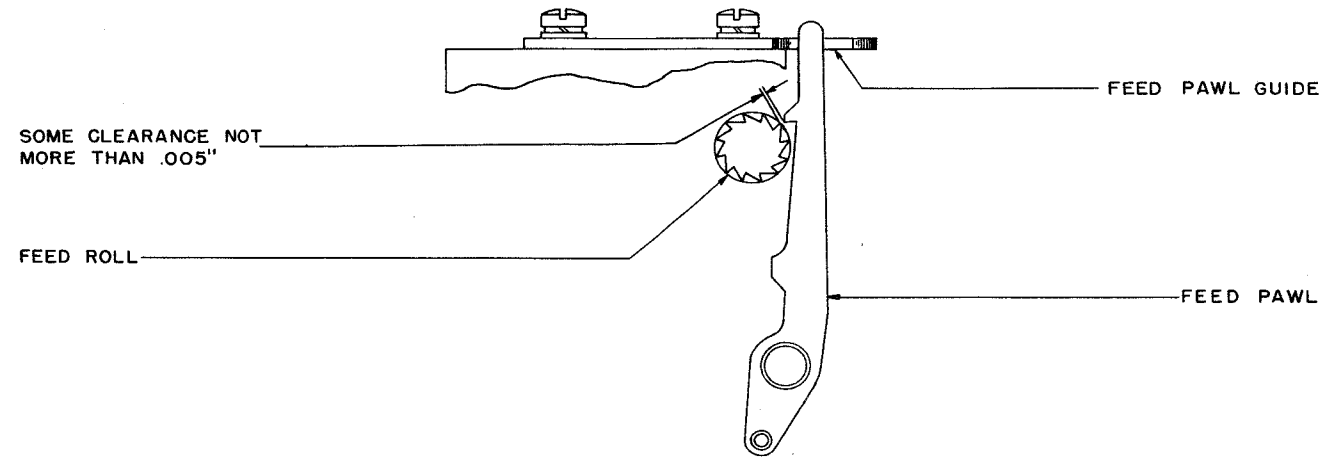

FIGURE 26

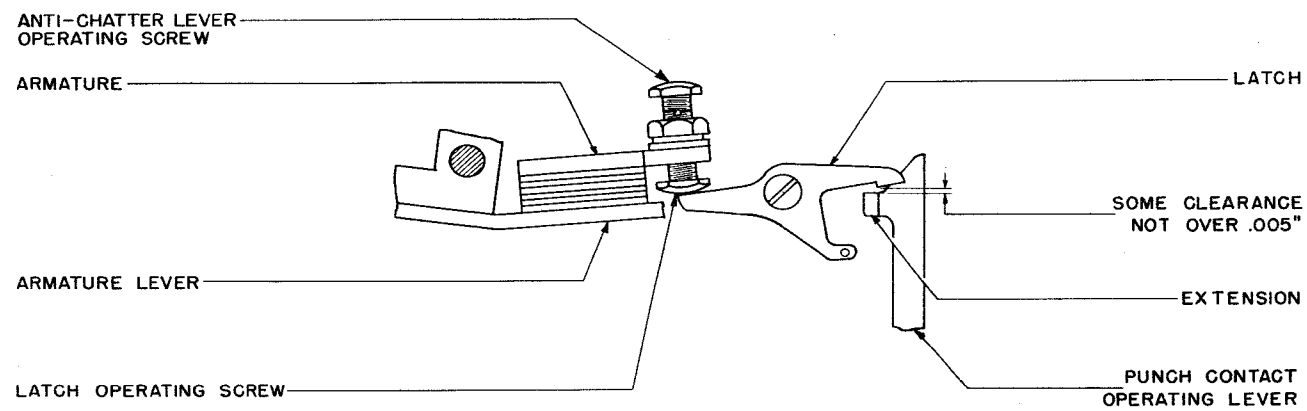

FIGURE 23

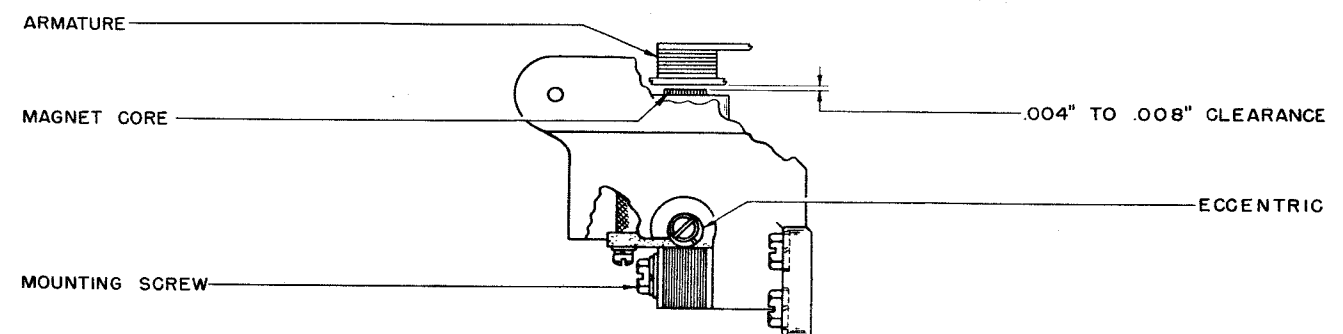

FIGURE 27

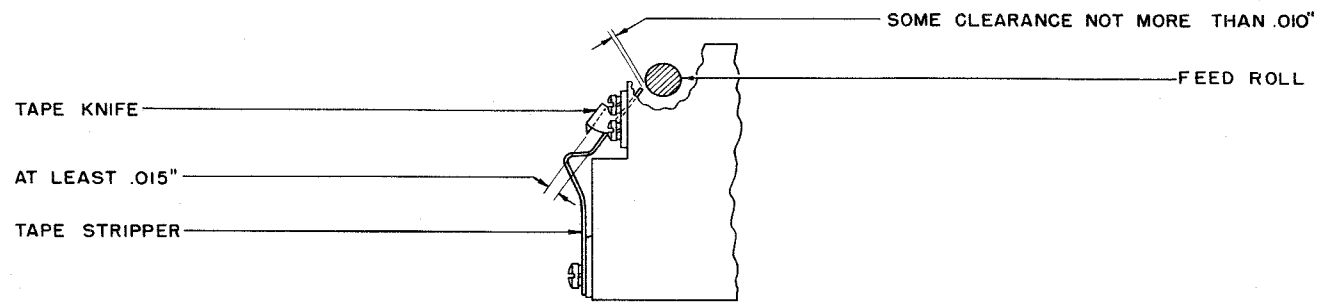

FIGURE 28

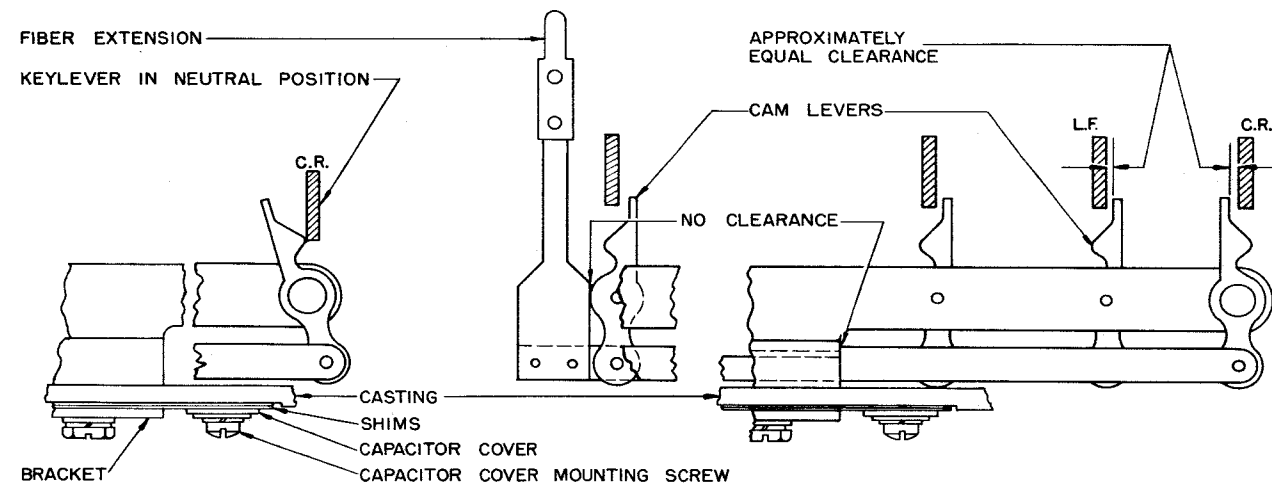

FIGURE 29

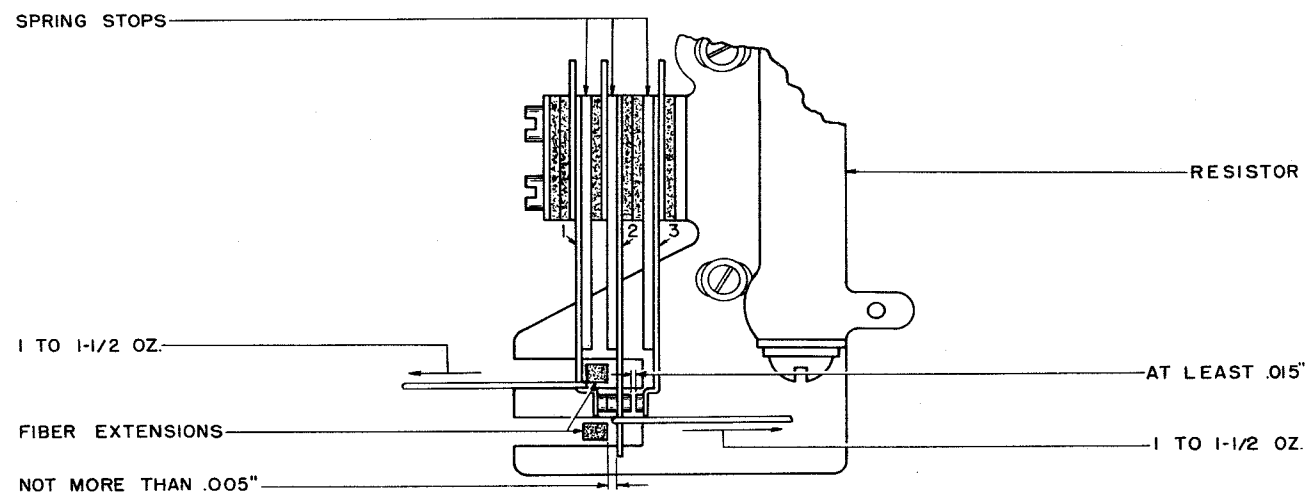

FIGURE 30

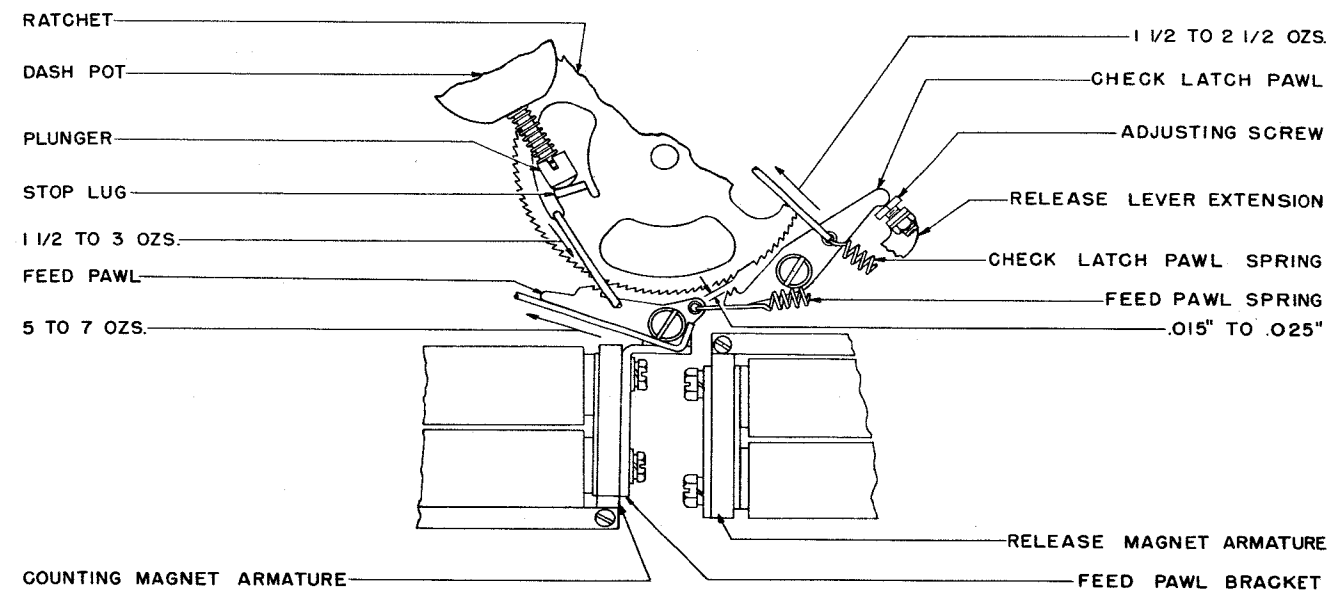

FIGURE 31

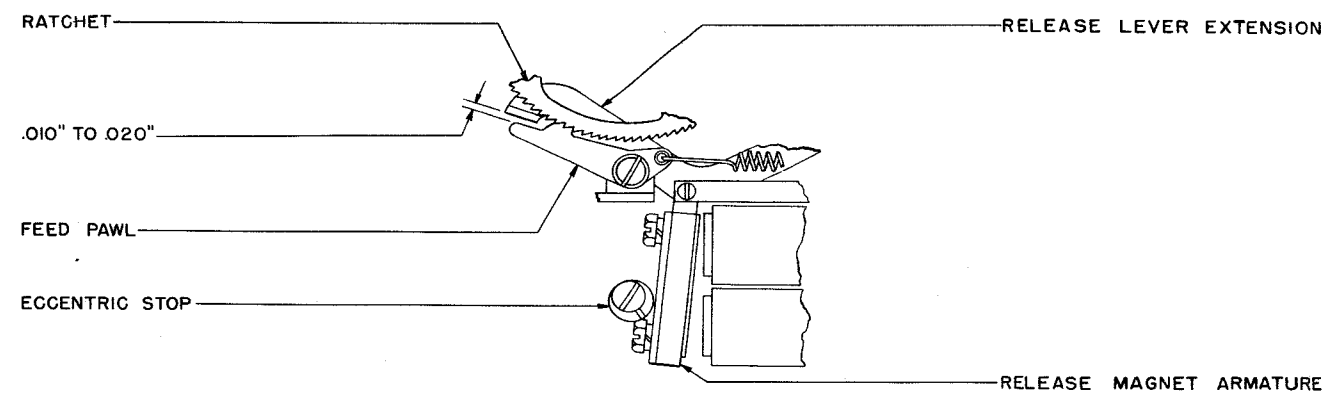

FIGURE 32

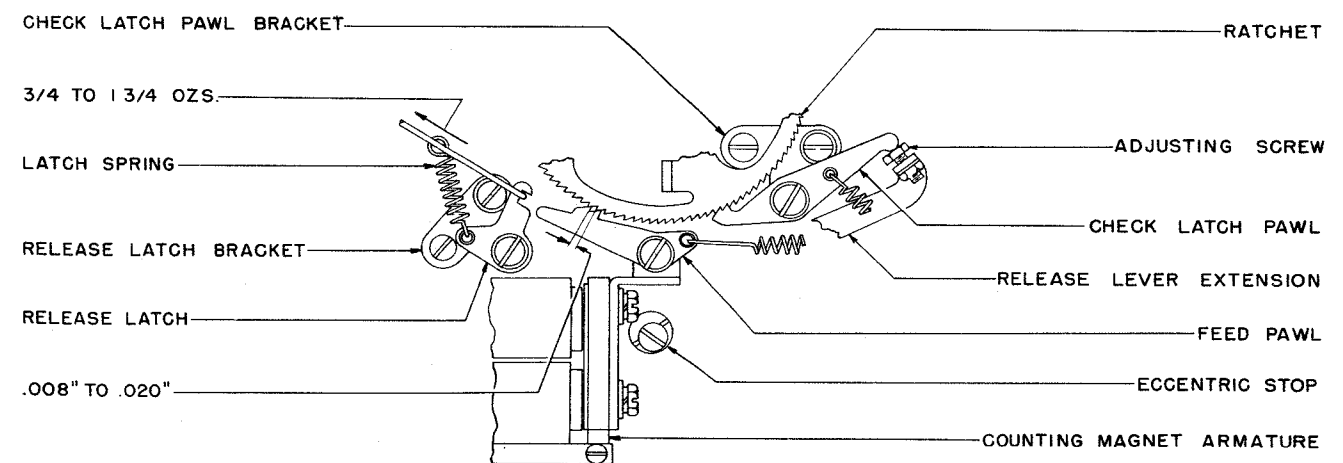

FIGURE 33

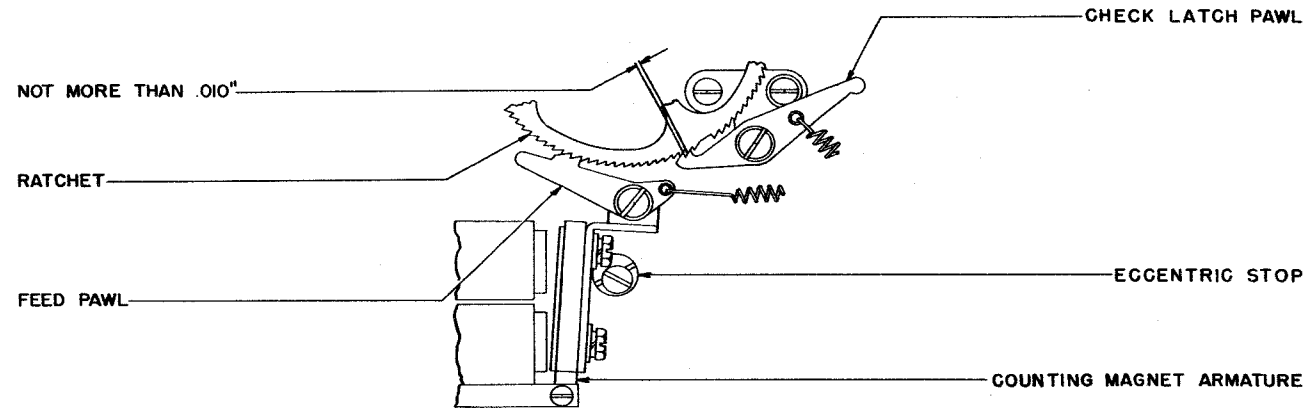

FIGURE 34

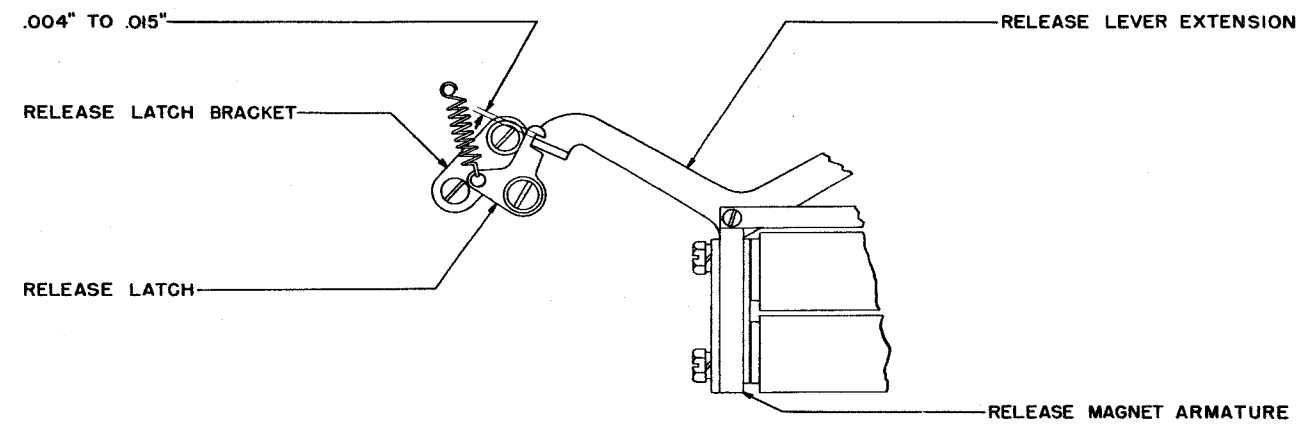

FIGURE 35

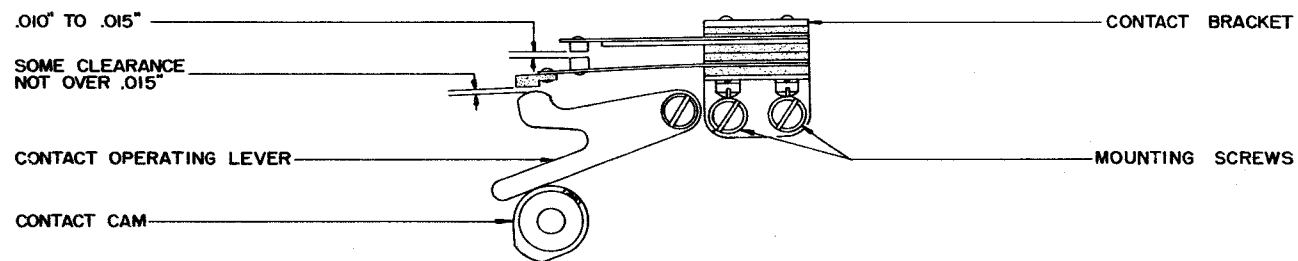

FIGURE 36

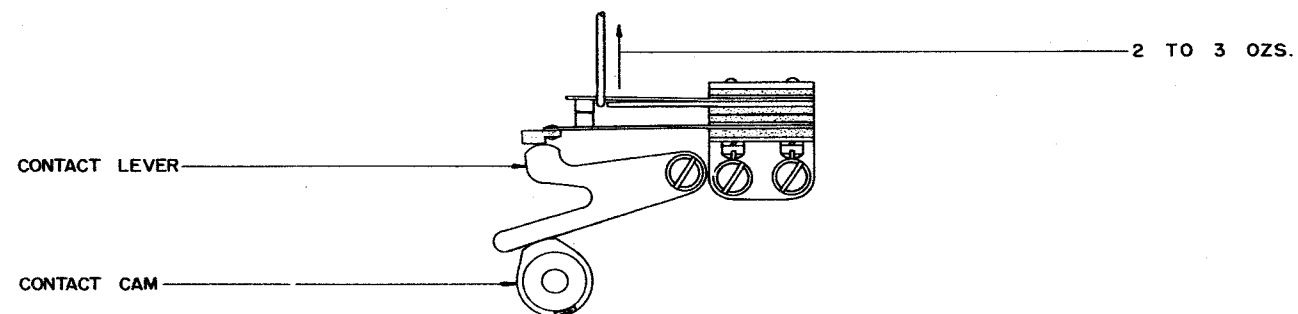
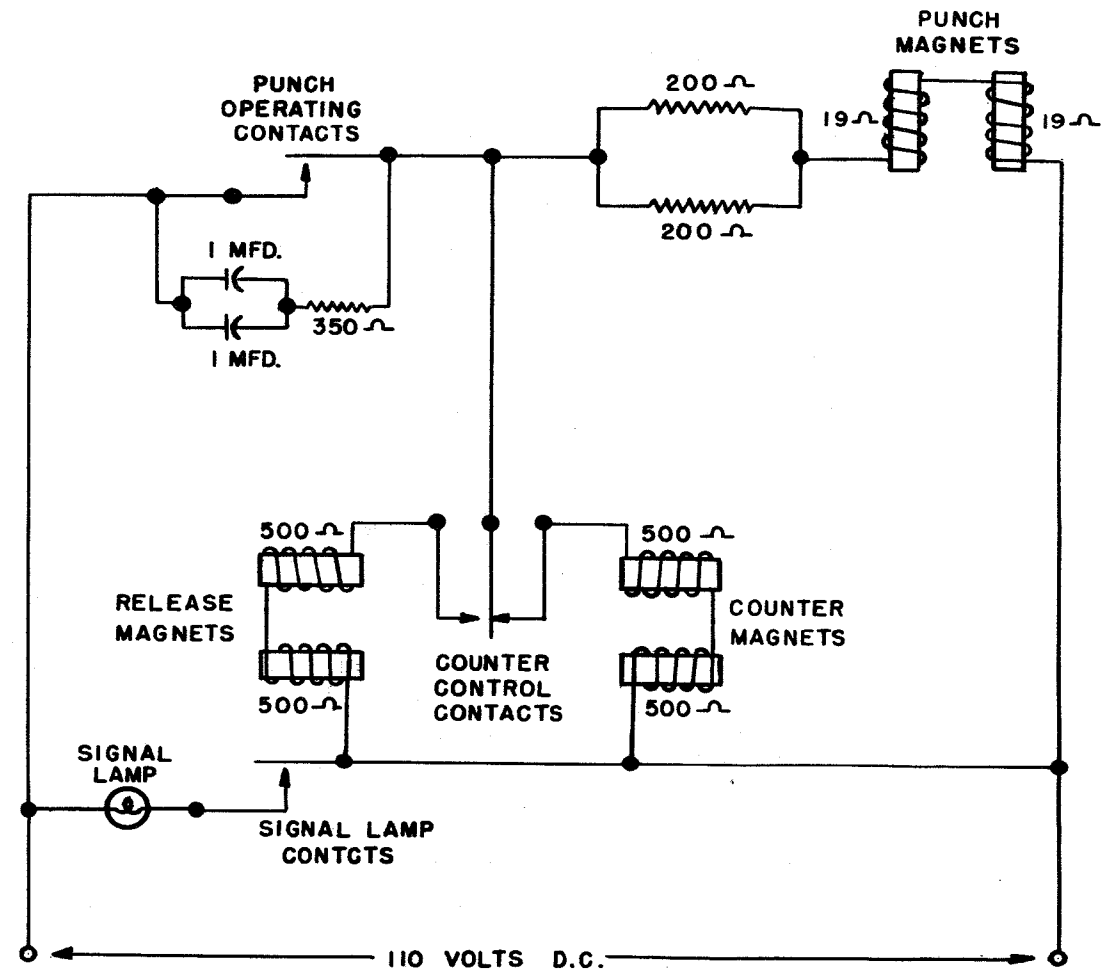

FIGURE 37



CIRCUIT DIAGRAM OF TAPE PERFORATOR (DPE)

FIGURE 38

REVISIONS

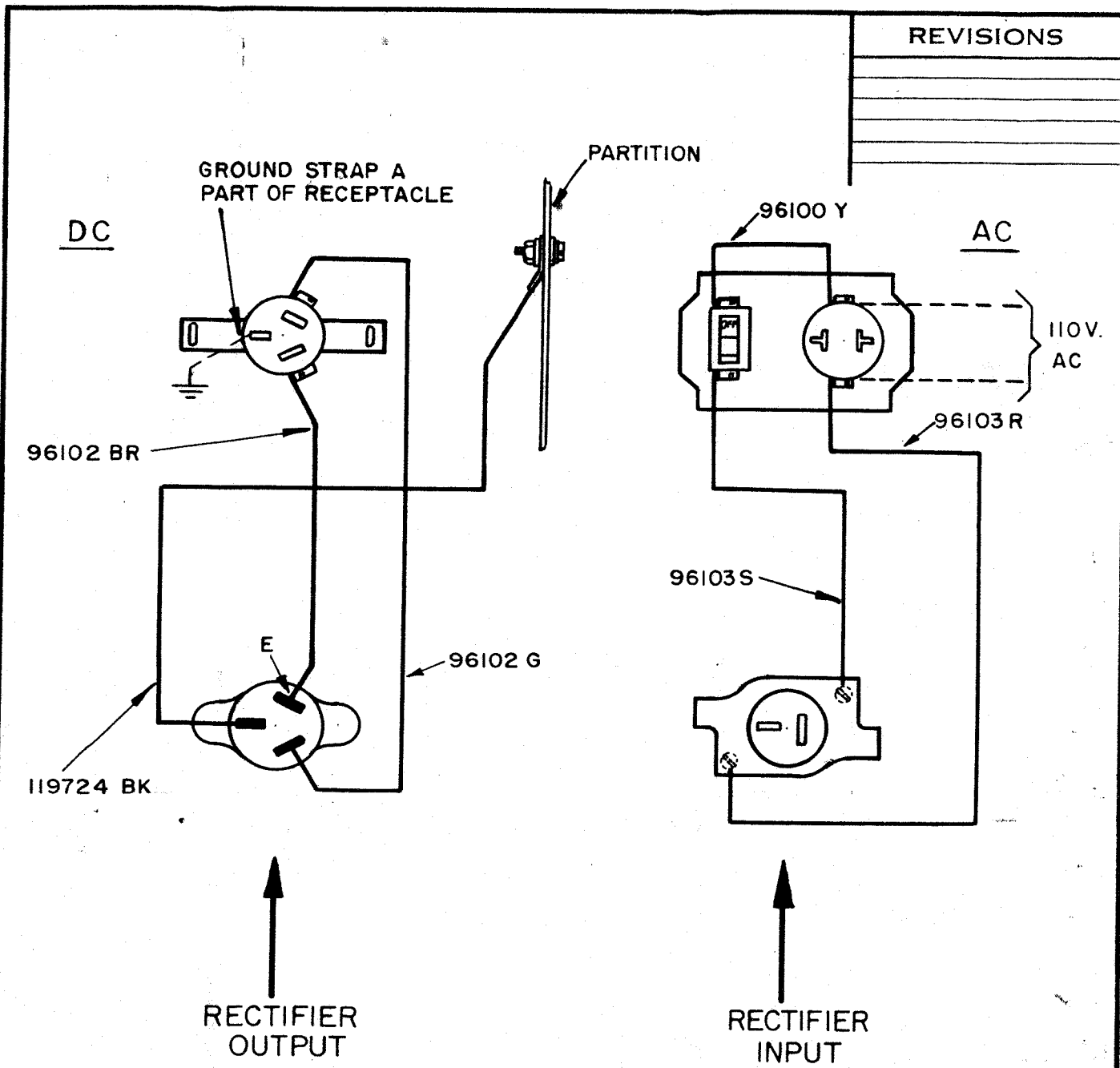

TABLE CONNECTIONS FOR VARIOUS POWER SUPPLIES		
A	POWER SUPPLY FOR PERFORATOR	POWER CONNECTIONS SEE NOTE C
1	RECTIFIER ON TABLE	CONNECT AS SHOWN
2	110V. D.C POWER SUPPLY EXTERNAL TO TABLE (EITHER + OR - GROUND)	DISCONNECT G, AND BR, WIRES FROM RECEPTACLE E. SPLICE AND TAPE G, AND BR, WIRES TO + AND - 110V. D.C.

NOTES:  
 A - RECEPTACLES AND PLUGS SHOWN FROM SLOT AND PRONG FACES.  
 B - ALL WIRES <sup>18</sup> C.C. DELTABESTON.  
 C - POWER WIRING MAY BE BROUGHT INTO ELECTRICAL SERVICE BOX THRU KNOCKOUTS PROVIDED IN BOTTOM.

2963-WD  
 DATE: 8-25-53

WIRING DIAGRAM FOR PET 202 TABLE

DRAWN: <i>FR</i>	APPROVED: <i>FR</i>
ENG'R'D: <i>ATB</i>	
CHECKED: <i>ATB</i>	
FILE: 30-42-AAA	
<b>TELETYPE CORPORATION</b>	