

### An RTTY Tape CW Keyer

DAVE LEE, WB6ULE  
1626 Warwick Lane  
Newport Beach, Cal. 92660

This keyer is a modified triple headed TD, the modification described here being used to enable the TD to send CW from a punched RTTY tape. This is a simpler system than that described by W0LQV in the November 1966 issue of CQ magazine. In this particular TD the contacts are all connected together. In order to modify it to send cw the bottom set of contacts must be split, between the third and fourth contacts. This is done by removing the screws that hold the contact assembly to the base and carefully sawing the bottom

RTTY JOURNAL  
set of contacts apart between the third and fourth contacts. Carefully reassemble the assembly adding a soldering lug to the side that was cut off enabling you to make connection to that side. The rest of the circuitry at this QTH was constructed in the TU case and a three wire cable connects the two units together. The circuit is connected to the 120 V. loop supply and the relay is set to operate on 60 ma. of loop current. In order to form the characters of code an ET is typed for a dash and a Z is used for a dit. Using one space between letters and two spaces between words and keying speed is about 16 WPM.

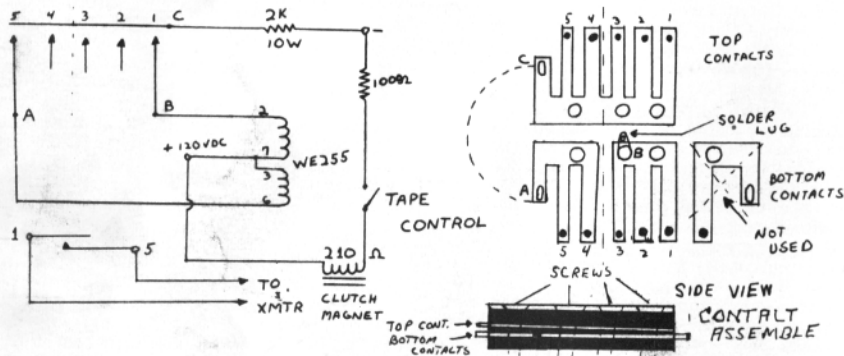

RTTY JOURNAL  
P.O. Box 837  
Royal Oak, Mich. 48068

First Class Mail



# RTTY JOURNAL

SEPTEMBER - 1967

EXCLUSIVELY AMATEUR RADIOTELETYPE

Vol. 15 No. 8

30 Cents

BONUS EDITION - 6 Extra Pages.

For the Winners of the 1967 RTTY Sweepstakes



Grand Award  
Runner up  
Awards.



THE MAINLINE TT/L-2 FSK  
DEMODULATOR

COMPLETE IN THIS ISSUE



# THE MAINLINE TT/L-2 FSK

## DEMODULATOR

KEITH PETERSEN, W8SDZ  
1418 Genesee Ave.  
Royal Oak, Mich. 48073

### DEVELOPMENT

The Mainline TT/L was originally published in "RTTY" magazine in November 1964. It was the result of nearly a year's work in design. Further improvements to the design were made, including the addition of the motor control system, and the improved version was published in August 1965 "QST".

The design of the TT/L has gone through continuous improvements because of the desire to make each part of the basic design as perfect as possible. Several modification sheets were distributed since the "QST" article and further improvements were made. The nature of these improvements is such that presenting a modification of the TT/L is rather impractical, so it was decided that the best solution would be to present an entirely new unit. This is the TT/L-2.

There has been some confusion with respect to the name chosen for the "squelch" circuitry, which was called the AUTOSTART stage in the "QST" article. Originally, this stage was called the AUTO-RECEIVE (Automatic Receive) stage. The new name was confused with the classic "Autostart" circuitry associated with simple motor control used in some VHF equipment. It was therefore decided that it would be wise to change the name back to the original AUTO-RECEIVE, which more accurately describes the operation of this stage.

The AUTO-RECEIVE stage in the TT/L-2 is significantly better than earlier designs because the time constant portion of the circuit has been entirely isolated from the triggering neon. Also, the charge voltage for the time constant capacitor is entirely determined by the signal itself because there are no "parallel-discharge" paths. This results in vastly improved performance.

Past designs of the TT/L did not include any protection against steady Space tones which cause the teleprinter to "run open". One of the modification sheets did have a simple "Anti-Space" circuit, but it was limited in its ability to cope with the

varying conditions of accuracy of tuning, limiterless operation, and Mark-only or Space-only operation. The new ANTI-SPACE circuit corrects these shortcomings, providing full protection against steady Space signals.

The MOTOR CONTROL stage has been simplified and stabilized. The new design offers additional versatility by having definite OFF-AUTOMATIC-ON switching.

The TT/L-2 incorporates a new simplified mode-switching system, utilizing a single six-position rotary switch, which eliminates much of the confusion resulting from the separate switches used in earlier designs. This switch controls four different functions, "interlocking" them so that there is no possibility of a wrong combination which could cause improper operation.

The new design offers heavy-duty Mainpower and Loop supplies for cooler operation and better regulation. This is especially important when the unit is used for continuous Autostart operation. And it is surprising to note that the cost is very nearly the same as the earlier design.

The EM84/6FG6 tuning eye has been retained because it continues to be a more accurate indicator than either a scope or meter. It shows, at a glance, when the signal has drifted and is especially effective when "straddle-tuning" is necessary due to inaccurate shift by the sending station.

The TT/L-2 includes filters and discriminators for both 850 Hz and 170 Hz shift because more stations are using narrow shift these days to take advantage of the reduction of QRM and noise.

Also included in the new design is a three-speed switch for the LOWPASS FILTER STAGE which allows optimum cutoff frequency for each speed. The increasing availability of equipment which will operate at higher speeds makes this feature especially timely.

### GENERAL DESCRIPTION

The Mainline TT/L-2 is an advanced-design FSK Demodulator offering high-performance FM (Limiter) and AM (Limiterless) reception of Radioteleprinter signals. The design includes both the unique patented "DTC" (Decision Thres-

hold Computer) and the improved "ATC" (Automatic Threshold Corrector) circuits. These circuits automatically control the incoming signal in a manner which allows Mark, Space, or both to provide normal reception. The unit has a dynamic range of approximately 60 DB which allows reception of deeply-fading signals.

Reception of either 850 Hz or 170 Hz signals is provided by two separate Bandpass Input filters and Linear Discriminators.

A special symmetrical limiter provides more than 60 DB of "zero time-constant" limiting. It also gives complete freedom from frequency-doubling. It is said to be one of the finest FM limiters available.

An extremely effective and accurate tuning indicator which directly compares the amplitude of Mark and Space signals is included.

Also included is a unique AUTO-RECEIVE (squelch) circuit which prevents the receiving teleprinter from printing garble when there is no signal. This circuit is designed in such a manner as to completely ignore CW and other non-RTTY signals which may be within the received passband.

The AUTO-RECEIVE circuit also controls a simple one-tube MOTOR CONTROL which turns off the teleprinter motor 30 to 45 seconds after the signal leaves. This delay is sufficient to keep the motor turned on during station-identification and subsequent "turn-over" to the other station. The combination of the AUTO-RECEIVE and MOTOR CONTROL stages provides an efficient and reliable Autostart system for unattended reception of RTTY signals.

A newly-developed ANTI-SPACE circuit keeps the printer from "running open" and prevents the AUTO-RECEIVE circuit from responding to steady Space signals.

Provision is made for reception of higher teleprinter speeds by the inclusion of a switchable three-speed LOWPASS FILTER.

Mode switching is extremely simple and straight-forward allowing full control of all functions while avoiding possible wrong combinations. This is done by grouping four different functions on one rotary switch.

The LOOP SUPPLY is of heavy-duty low-hum design. It provides balanced voltage output for direct-drive of a saturated-diode FSK or AFSK circuit. It also features AUTOMATIC RE-TRANSMISSION of received signals -- such as relaying

from another band or playback from a tape-recorded signal.

The MAIN POWER SUPPLY is of heavy-duty design to provide reliable continuous operation. Voltage regulation is provided for critical circuits so that the unit will operate normally with A.C. line voltages from 105 to 125.

### CIRCUIT DESCRIPTION

#### 1. BANDPASS INPUT FILTER

Two bandpass input filters are provided. These filters are 3-pole Butterworth design and utilize the commonly-available 88-MH toroids. The use of these toroids in the design necessitated a higher impedance than normal; but this is advantageous in that when simple resistor impedance matching is used, a decoupling action takes place which isolates the filters from any reactance in the receiver output circuit, and at the same time provides a constant load for this output circuit.

The bandwidth of the filter for 850 Hz shift is approximately 1,000 Hz. This filter requires no tuning if five percent capacitors are used.

The bandwidth of the filter for 170 Hz shift is approximately 275 Hz. A complete description and tune-up instructions for this filter appeared in the September 1966 issue of "QST". The individual sections of this filter are tuned to 2200 Hz utilizing a special procedure outlined in that article.

#### 2. AMPLIFIER STAGE (V-1)

This stage amplifies the output of the BANDPASS INPUT FILTER and is transformer-coupled to either the first limiter input or directly to the discriminator, depending on the position of the LIMITER BY-PASS switch. Transformer-coupling is used for two reasons. (1) It provides the necessary impedance matching and voltage step-up between the plate of the AMPLIFIER STAGE and the grid circuit of the first limiter; (2) It provides a "zero time constant" drive for the first limiter grid circuit.

#### 3. LIMITER STAGE (V-2 & V-3)

Limiting is provided by two 6BN6 tubes in cascade. Both stages are transformer-driven to provide more than 60 DB of "zero time constant" limiting. The 6BN6 is said to be one of the finest FM limiters available today. It provides "symmetrical limiting" which eliminates the possibility of frequency-doubling and also provides much-improved limiter performance compared to older types of limiters.

The IN-OUT switch is provided to by-



pass the limiters when Limiterless (AM) copy is desired. This method of switching from FM to AM reception eliminates the need for separate input stages for each mode.

#### 4. FILTER SECTION

Two linear discriminators are provided -- one for 850 Hz shift and one for 170 Hz shift reception. Any shift from 4 Hz to over 1,000 Hz may be received by utilization of "straddle-tuning". No re-tuning of the discriminators is required.

Commonly-available 88-MH toroids are used for best stability and freedom from inductive pickup. Extra switch positions are available should the user desire to install the narrow-band 3-pole Butterworth Mark and Space channel filters described in September 1966 "QST" on page 34. (This information was not reprinted here because of space limitations. Back issues of "QST" are usually available at the nearest public library for reference). These filters were not included in the design as it was felt that the builder might wish to add them at a later date, after becoming better acquainted with the operation of the TT/L-2.

One example of an arrangement using the narrow-band filters would be where the user builds the 2125, 2295, and 2975 filters. The 2125 Hz filter would be connected to both the A MARK and B MARK switch positions. The 2975 Hz filter would be connected to the A SPACE switch position. The 2295 Hz filter would be connected to the BSPACE switch position. The switch could then be marked, from left to right, 850 DISC, 850, 170, 170 DISC.

#### 5. DRIVER STAGE (V-4)

This circuit uses a standard transformer-coupled 12AT7 amplifier to amplify Mark and Space signals from the filter section. The transformer secondary voltages are very high -- 50 to 100 volts RMS being typical -- to provide for a very wide dynamic range in the detector stage. The secondary connections marked SCOPE MARK and SCOPE SPACE may be connected to an external oscilloscope to be used as an auxiliary tuning indicator. Be sure that the scope has a high impedance input so it does not load down the circuit. One simple and inexpensive scope appeared in the June 1967 issue of "RTTY Journal" on page 3.

The SCOPE MARK and SCOPE SPACE terminals would be used for connection to the Mainline TT/O Semi-counter. This is a very worthwhile unit to add as it allows

even more precise tuning. In addition, the user may measure the shift of an incoming signal. This TT/O was described in May 1966 "QST" on page 35. (This article is one of a series by Hoff, beginning in January 1965 "QST", and is recommended reading for all RTTYers. The series represents one of the most up-to-date compilations of information on RTTY operation and equipment).

#### 6. DETECTOR STAGE

This stage uses two standard parallel-combined detectors. The polarities of one detector are the opposite of the other in order to provide a Mark and Space voltage of identical polarity for the tuning indicator and AUTO-RECEIVE stages. This voltage is obtained through an "OR GATE" which consists of two diodes hooked across the contacts of the NORMAL-REVERSE switch.

#### 7. LOWPASS FILTER STAGE (V-5)

This stage consists of two cathode followers and a 3-pole Butterworth Low-pass filter. The left-hand cathode follower is used to provide a low-impedance drive source for the filter and to isolate it from the detector stage. The right-hand cathode follower is used to isolate the lowpass filter output from the DTC/ATC STAGE and provides a low-impedance drive source for that stage. A four-pole, three position, rotary switch is used to select the proper components for optimum cut-off frequency for 60, 75, or 100 WPM signals. This switch is shown in the 60 WPM position on the diagram. It is thus clearly seen which components associated with the other two positions may be omitted if the builder is not interested in 75 or 100 WPM.

The test point is provided for convenient connection of a meter for use during the balance and set-up procedure.

#### 8. DTC/ATC STAGE

The Decision Threshold Computer and Threshold Corrector circuit processes the detected signal so that Mark and Space are automatically centered around "zero". The effect is to correct for mistuned or drifting signals when FM reception is employed, and to give proper decision level to the variable-amplitude Mark and Space signals received when AM (Limiterless) reception is employed. The DTC position is used for all reception except Mark-only or Space-only which requires the ATC circuit for proper reception.

A complete discussion and explanation

of the DTC/ATC circuit appeared in the December 1964 issue of "RTTY" magazine.

#### 9. SLICER STAGE (V-6A & V-7)

This stage consists of a cathode follower (V-6A) and a Schmidt trigger (V-7). The cathode follower is to isolate the DTC/ATC circuit from the input of the Schmidt trigger to avoid loading effects. The Schmidt trigger is a standard type which provides an input sensitivity of approximately 30 millivolts. A balance control is provided to adjust the cathode bias so that the tube will trigger properly. See adjustment instructions for details.

#### 10. "OR GATES"

The OR GATES consist of three diodes hooked to a common point to provide Marking voltages to the 6W6 keyer stage. These diodes prevent "backing up" of the positive voltages from the three circuits that drive this common point. The 6W6 receives marking voltages from either (1) the SLICER STAGE, (2) the AUTO-RECEIVE STAGE, or (3) the ANTI-SPACE STAGE.

#### 11. KEYSER STAGE (V-8)

This stage utilizes a triode-connected 6W6 to key the loop circuit. The circuit is designed so that the incoming signal, as well as the local teleprinter, can key the FSK voltage output. This allows the operator to re-transmit any incoming signal from another band or from a tape recorder. From this it can be seen that the user must open the EXTERNAL STANDBY switch while he is transmitting so that his own signal will not feed back into the loop. Of course, when re-transmitting the switch must remain closed.

#### 12. LOOP SUPPLY & FSK DRIVER

The Loop Supply utilizes a heavy-duty line-isolation transformer and bridge rectification for excellent regulation and low hum level. The printer, keyboard, and other teleprinter equipment are connected in series with the 60 MA loop. This allows normal operation of all equipment. Direct-drive of a saturated-diode FSK or AFSK circuit is provided by sampling the loop signal through a simple resistor bridge circuit. The system is all-electronic -- no relays are used.

The FSK VOLTAGE BALANCE control is provided to allow adjustment for exactly equal mark and space voltages to prevent distortion of the transmitted signal.

The 1250 ohm 20 watt resistor sets the loop current. This resistor is not adjustable because its value has been chosen to

provide proper operation of the loop circuit with varying A.C. line voltages.

#### 13. MAIN POWER SUPPLY

This supply uses a heavy-duty power transformer which is rated by the manufacturer for 110 MA with a capacitor-input filter, and 140 MA with a choke-input filter. This rating is well above the actual current drain of the unit and provides for very cool operation. Choke-input filtering is used in both the positive and negative circuits for best regulation. The plus and minus 150 volt regulators are both OD3/VR-150 tubes. This type was chosen because it has a wider regulating current range than the miniature OA2. The VR-tube dropping resistors have been chosen to provide proper operation of the regulators over a wide range of power line voltages. The rectifiers are special "avalanche" type 800 PIV 500 MA silicon diodes. They provide built-in protection against reverse transient overvoltage spikes. Large filter capacitors are used to give low hum and good dynamic regulation.

#### 14. TUNING INDICATOR (V-11)

This stage uses an EM-84/6FG6 single-bar tuning eye. The circuit is arranged so that both Mark and Space close the eye equally when the signal is turned in correctly. The INDICATOR SENSITIVITY pot is provided so that the user may control the amount of eye closure to suit his preference. The best setting is one where the eye just closes. If the signal drifts the eye immediately starts to open, signaling the operator to retune.

The B-plus source for this tube is 150 volts regulated. This provides two advantages. (1) Freedom from variations in the amount of eye closure due to the line-voltage variations; (2) Increased fluorescent target life due to the lower-than-normal voltage. The brightness is more than adequate for operation in a normally-lighted room.

#### 15. AUTO-RECEIVE STAGE (V-12A & V-13)

This stage consists of: (1) a cathode follower, (2) an R-C time constant network, (3) a D.C. amplifier/neon trigger, (4) a second D.C. amplifier/neon coupler.

The cathode follower is used to isolate the R-C time constant network from the high-impedance source of signal voltage. The grid has a diode clamp to prevent it from going positive.

The R-C time constant network is arranged to have slow-attack and fast-re-

lease. This prevents CW and other non-RTTY signals from fully charging the capacitor.

The first D.C. amplifier is used to control the triggering neon in its plate circuit. The gain of this stage provides for exceptionally sensitive triggering action. This allows the circuit to easily distinguish between the d.c. levels of signal and noise.

The second D.C. amplifier is used to control the neon coupler which feeds into the "OR GATE" to provide an artificial Marking voltage for the 6W6 keyer tube when there is no signal. This amplifier's cathode bias is stabilized with a zener diode so that its keying point will always be the same with varying line voltages. When the standby switch is opened, the cathode circuit is biased heavily positive, causing this tube to be cut off. This allows the neon coupler to fire, applying a marking voltage to the 6W6 keyer.

The AUTO-RECEIVE circuit was designed to be used only when receiving in the FM (Limiter) mode. When the AM (limiterless) mode is used, the function switch (S-8) should always be in the number five position.

#### 16. ANTI-SPACE STAGE (V-6B & V-14A)

This stage consists of: (1) a cathode follower (V-6B), (2) an R-C time constant network, (3) a D.C. amplifier/neon trigger.

The cathode follower (V-6B) is used to provide isolation from the slicer stage and to give a low impedance source for the R-C time constant network.

The R-C time constant network is arranged to have slow-attack and fast-release. This allows it to distinguish between normal teleprinter signals and steady Space signals.

The D.C. amplifier (V-14A) is used to control the neon trigger which feeds a positive voltage into the "OR GATE" to provide an artificial Marking signal for the 6W6 keyer tube when a steady Space signal is received. The neon trigger also applies a positive voltage to the grid of the AUTO-RECEIVE cathode follower (V-12A), causing the diode clamp to saturate. This effectively grounds the AUTO-RECEIVE STAGE input and makes that stage operate as if no signal was being received. Thus it can be seen that steady Space signals are rejected entirely.

#### 17. MOTOR CONTROL STAGE (V-14B & V-12B)

This stage consists of: (1) a D.C. amplifier (V-14B) to operate the motor

control relay, (2) a timing network consisting of an R-C time constant network and a neon trigger, (3) a clamp tube (V-12B).

The D.C. amplifier is directly controlled by the AUTO-RECEIVE STAGE so that when a signal is received the teleprinter motor is turned on. When the signal leaves, the motor remains turned on. The artificial Marking voltage which is applied to the "ORGATE" by the AUTO-RECEIVE STAGE is also applied to the R-C time constant network and neon trigger. When the charge on the capacitor builds up sufficiently, the neon fires -- turning OFF the motor.

The clamp tube (V-12B) is actuated during "STANDBY" and "MOTOR ON" modes of operation to prevent triggering of the neon. It does this by discharging the time constant capacitor.

A complete discussion of this stage appeared in the February 1967 issue of "RTTY Journal" on page 6.

The MOTOR CONTROL STAGE works only when the AUTO-RECEIVE circuit is in operation.

The A.C. line voltage for the teleprinter is obtained from the main power switch so that the machine will be turned off when the TT/L-2 is off.

#### ADJUSTMENT INSTRUCTIONS

Allow the unit to warm up for at least fifteen minutes before ANY adjustments are made. The tubes will age during the first few days of operation so it is wise to repeat the entire adjustment procedure about a week after initial set-up.

These adjustments should always be done in the order shown below or improper operation will result.

##### 1. CATHODE FOLLOWER BALANCE

This is the first adjustment to be made. Connect a sensitive VOM or VTVM to the test point. Remove all audio input to the TT/L-2 by unplugging the input cable. Set the LIMITER BYPASS switch to the OUT position. Adjust the CATHODE FOLLOWER BALANCE pot for zero voltage at the test point.

##### 2. SLICER BALANCE

This adjustment is also made with no audio input and the limiter bypassed.

The ANTI-SPACE switch (S-9) should be set to the OFF position for this adjustment.

Turn the SLICER BALANCE pot until the teleprinter "runs open". Turn the pot in the opposite direction until the printer returns to marking. Note these two points

and set the pot mid-way between them. No further adjustment is necessary.

Return the ANTI-SPACE switch to the ON position.

##### 3. FILTER STAGE

The discriminators should be tuned to the desired tone frequencies by varying the capacitors marked with asterisks. During the tuning procedure, the resistors in series with the ground connection of the toroids should be temporarily shorted out. Be sure to remove these shorts after the tuning is completed or severe distortion of the received teleprinter signals will result. For additional hints on tuning refer to the article in September 1966 "QST".

The resistors marked with asterisks on either side of the balance pot should be chosen so that the Mark and Space voltages, when balanced, do not exceed sixty volts plus or minus at the test point. If it becomes necessary to change the value of these resistors, be sure to change them both an equal percentage so as to maintain a balance within the range of the pot.

Adjustment of the DISCRIMINATOR BALANCE pot is made with the LIMITER BYPASS switch set to the IN position and the NORMAL-REVERSE switch set to the NORMAL position.

Apply alternately a Mark and Space signal to the input of the TT/L-2. Adjust the DISCRIMINATOR BALANCE pot so that the Mark and Space voltages are equal, but of opposite polarity, at the test point.

##### 4. INDICATOR BALANCE

After the discriminators have been balanced, set the NORMAL-REVERSE switch to the REVERSE position and adjust the INDICATOR BALANCE pot for equal Mark and Space voltages at the test point.

Observe the tuning eye. If there is any movement when alternating Mark and Space, carefully adjust the INDICATOR BALANCE pot to eliminate it. No further adjustment is necessary.

##### 5. FSK VOLTAGE BALANCE

Set the rotary function switch (S-8) to positive 4 (standby). Alternately open and close the loop by pushing the "break key" or opening the keyboard contacts of the teleprinter. Adjust the FSK VOLTAGE BALANCE pot for equal, but opposite, Mark and Space voltages. Mark should be approximately minus 45 volts and Space should be approximately plus 45 volts. No further adjustment is necessary.

##### 6. AUTO-RECEIVE SENSITIVITY

It is best to use your receiver's 100 KHz crystal calibrator or an actual signal for this adjustment. Set the rotary function switch (S-8) to position 2 (Auto-Receive, Motor on).

With no signal (just noise) input to the TT/L-2, adjust the AUTO-RECEIVE SENSITIVITY pot to a point just below where the teleprinter prints garble. The printer should now remain quiet.

Adjust the sensitivity pot so that when a signal is applied there is a delay of 3 to 4 seconds before the "RCVE" neon indicator lights. If your adjustment is correct, the teleprinter should print five or six letters after the signal leaves and then remain quiet.

#### THE MAINLINE FSK KEYS

The Mainline FSK Keyer is a "saturated diode" circuit in which the diode operates as an electronic switch to apply the shift trimmer capacitor to the VFO or PTO circuit. The TT/L-2 provides the necessary voltages to drive this circuit.

The advantages of a saturated-diode system are: (1) freedom from frequency and shift variations due to changes in driving voltage; (2) freedom from hum pickup in the wiring that connects it to the TT/L-2 (no shielding of this lead is necessary); (3) narrow shift CW ID easily applied; (4) additional keyers may be paralleled for other shifts--without affecting the VFO. Switching from one shift to another is a simple matter of switching the TT/L-2 voltage source from one keyer to another.

Only a few simple precautions are necessary for proper operation of this FSK circuit--(1) be sure that the keyer is mounted very close to the VFO or PTO so that a short connecting lead may be used; (2) be sure to use an "NPO" type miniature ceramic trimmer for best stability; (3) use only an RF choke wound on a ceramic form (ferrite or iron-core types are not suitable because of excessive internal capacitance so the National type R-50 is recommended); (4) use only the 1N270 diode specified (this diode is a special high-conductance computer type which allows maximum circuit "Q" to avoid variations in oscillator output level).

If reversed-shift is desired, simply reverse the 1N270 diode.

#### PROPER AUDIO INPUT LEVELS

The proper audio input level for the TT/L-2 is that which produces the same amount of tuning-eye closure in either FM

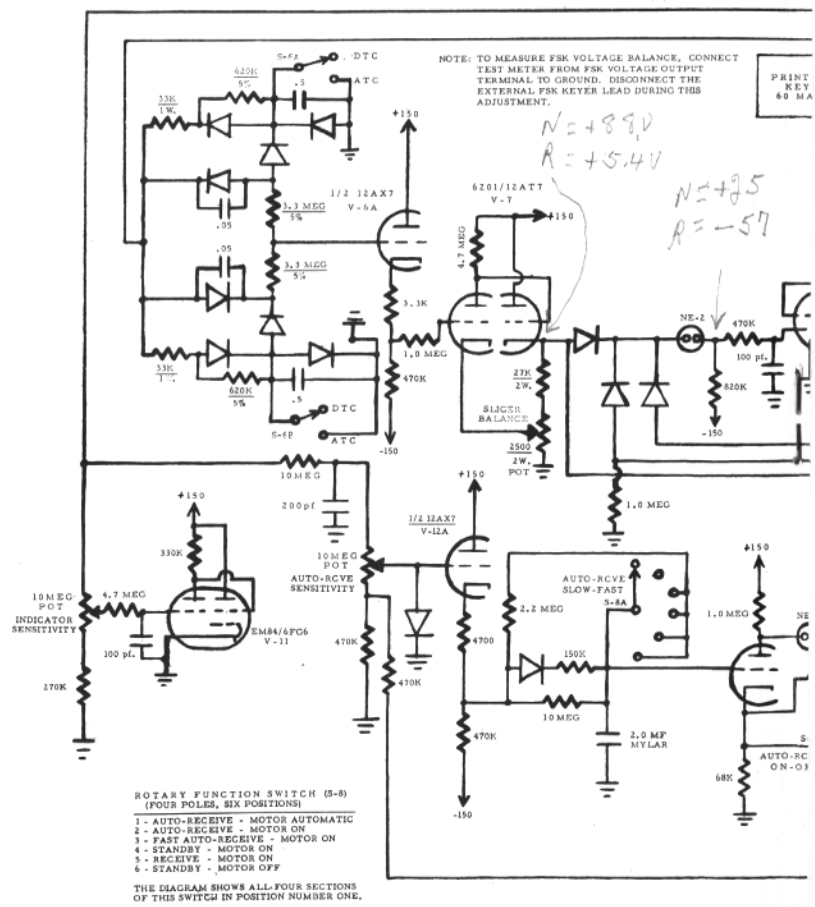
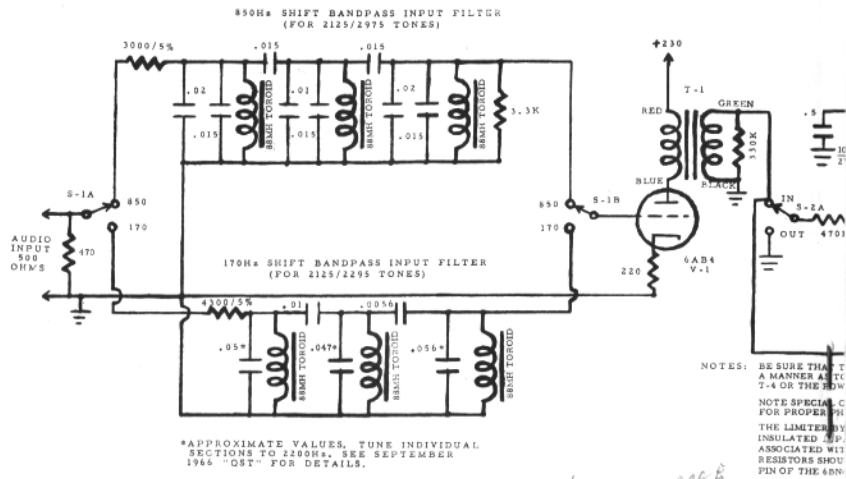

(Limiter) or AM (Limiterless) modes of operation. You will find that this is slightly above normal room volume and it will be necessary to install a pad in the speaker circuit to bring its volume down to a suitable listening level. The pad offers two advantages: (1) it decouples the variable impedance of the speaker from the receiver output circuit; (2) it helps prevent pickup of room noise by the speaker which could couple into the TT/L-2 input and cause interference to the desired signal.

CONSTRUCTION NOTES

The layout used for construction of the TT/L-2 should be similar to that used in a high-quality audio pre-amp. This is desirable because of the very high-gain circuitry used. Be sure to shield all audio and high-impedance DC leads which might pick up extraneous signals or noise due to physical length or placement.

The wiring associated with the grids of V-1, V-5A (left-hand section), V-6A and V-12A should be very short or shielded.

All wiring associated with LIMITER BYPASS switch should be shielded.

It is most important that T-1 and T-2 transformers be mounted in such a way that they will not pick up inductively from each other, from T-3 and T-4, or from the power supply transformers and chokes. The best method to assure this is to mount T-1, T-2, T-3 and T-4 on different axes. Do not mount one above and one below the chassis in an effort to avoid inductive coupling because the usual aluminum chassis used will not provide inductive shielding.

All switches, except S-9, should be mounted on the front panel.

The AUTO-RECEIVE SENSITIVITY and the INDICATOR SENSITIVITY pots should be mounted on the front panel. All other pots should be mounted on the rear panel.

The test point located at the cathode of V-5B (right-hand section) should be mounted in a convenient spot on or near the rear panel.

You will notice that no power-on indicator has been included in the design. It was purposely omitted because the tuning-eye provides this indication.

The RCVE and STBY neon indicators may be mounted on the front panel, if desired, to show when the unit is ready to receive a signal. If the builder does not wish to include these indicators, the RCVE neon and its resistor may be omitted, but the STBY neon must be retained as it is

used for other purposes.

The rotary function switch (S-8) should be a shorting type such as the Centralab PA2010. The BANDPASS FILTER switch (S-1) and the LIMITER BYPASS switch (S-2) should be non-shorting type switches such as the Centralab 1464. The FSK & MAIN POWER switch (S-7) should be a 15-AMP toggle switch such as the Arrow-Hart & Hegeman type 82607.

SPECIAL NOTES

A complete package of parts for construction of the TT/L-2 is available, at a considerable savings, from Newark Industrial Electronics Corp., 2114 South Division Avenue, Grand Rapids, Michigan-49507, attention Truman Boerkoel, K8JUG. All specified parts, except for the 88-MH toroids, are included. If the builder prefers to buy only certain specific parts, they are available from this same source and will be shipped on the same day the order received.

A fiberglass-epoxy printed circuit board for construction of the TT/L-2 is available at very reasonable cost from James R. Salter, K5BQA, 11040 Creekmore, Dallas, Texas-75218. This board is well-constructed and designed to match the physical sizes of the parts included in the package listed above.

All filters and discriminators for the TT/L-2, including the narrowband 3-pole Butterworth Mark and Space channel filters, are available at very reasonable cost from Harman Zachry, WA6JGI, 3232 Selby Avenue, Los Angeles, California-90034.

For further details, send self-addressed, stamped envelopes to the above addresses.

ACKNOWLEDGEMENTS

Special thanks go to Truman Boerkoel, K8JUG, for his suggestions on specification of parts and for his interest in this project which prompted him to offer the package of parts mentioned above; to Irvin Hoff, W6FFC, for providing the design of the new 3-speed lowpass filter and for his suggestions on the most convenient arrangement of the positions of the rotary function switch; to Ralph Leland, W8DLT, for drawing the final schematic, for suggestions on its labeling, and for general moral support; to Dusty Dunn, W8CQ, for his patience with a person who is engineer first and writer second; to Jim Salter, K5BQA, for his interest in this project which prompted him to offer the new

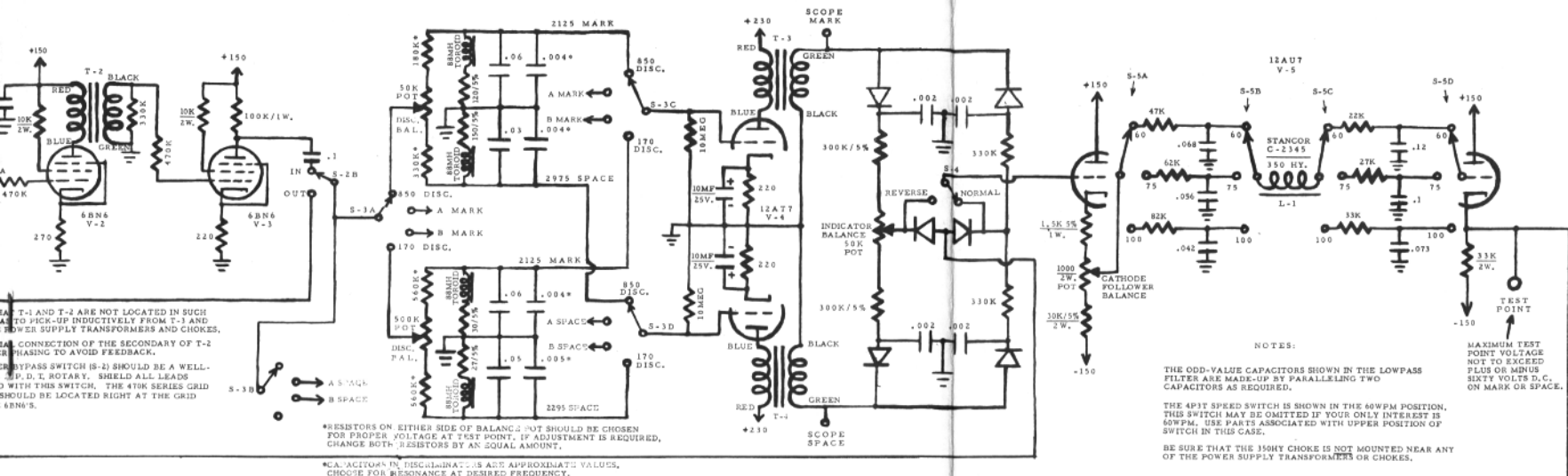

\*RESISTORS ON EITHER SIDE OF BALANCE POT SHOULD BE CHOSEN FOR PROPER VOLTAGE AT TEST POINT. IF ADJUSTMENT IS REQUIRED, CHANGE BOTH RESISTORS BY AN EQUAL AMOUNT.

\*CAPACITORS IN DISCRIMINATOR ARE APPROXIMATE VALUES. CHOOSE FOR RESONANCE AT DESIRED FREQUENCY.

NOTES:

THE ODD-VALUE CAPACITORS SHOWN IN THE LOWPASS FILTER ARE MADE-UP BY PARALLELING TWO CAPACITORS AS REQUIRED.

THE 4P3T SPEED SWITCH IS SHOWN IN THE 60WPM POSITION. THIS SWITCH MAY BE OMITTED IF YOUR ONLY INTEREST IS 60WPM. USE PARTS ASSOCIATED WITH UPPER POSITION OF SWITCH IN THIS CASE.

BE SURE THAT THE 350HT CHOKE IS NOT MOUNTED NEAR ANY OF THE POWER SUPPLY TRANSFORMERS OR CHOKES.

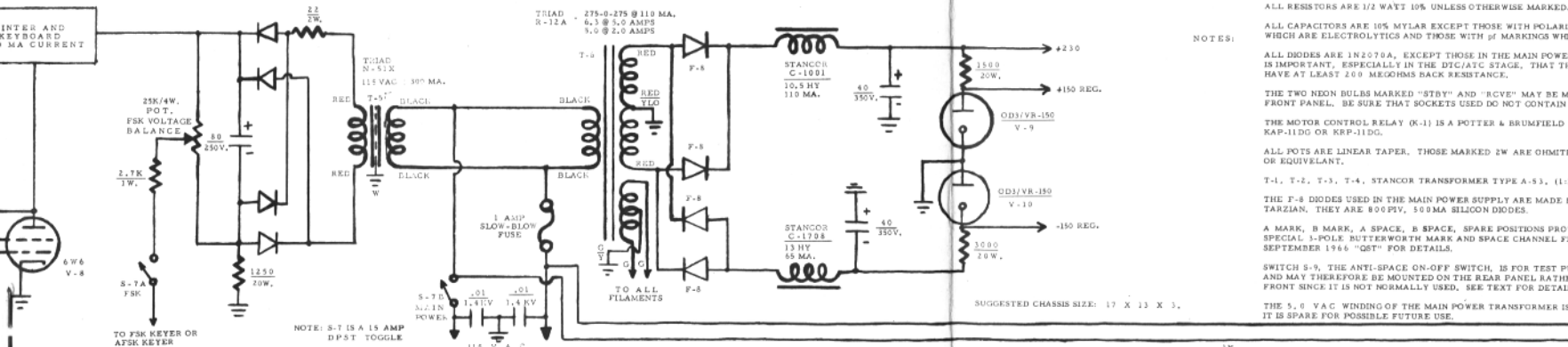

NOTES:

ALL RESISTORS ARE 1/2 WATT 10% UNLESS OTHERWISE MARKED.

ALL CAPACITORS ARE 10% MYLAR EXCEPT THOSE WITH POLARITY MARKINGS WHICH ARE ELECTROLYTICS AND THOSE WITH  $\mu$  MARKINGS WHICH ARE MICA.

ALL DIODES ARE 1N2078A, EXCEPT THOSE IN THE MAIN POWER SUPPLY. IT IS IMPORTANT, ESPECIALLY IN THE DTC/ATC STAGE, THAT THE DIODES USED HAVE AT LEAST 200 MEGOHMS BACK RESISTANCE.

THE TWO NEON BULBS MARKED "STBY" AND "RCV" MAY BE MOUNTED ON THE FRONT PANEL. BE SURE THAT SOCKETS USED DO NOT CONTAIN ANY RESISTORS.

THE MOTOR CONTROL RELAY (K-1) IS A POTTER & BRUMFIELD 110 VDC TYPE KAP-11D0 OR KEP-11D0.

ALL POTS ARE LINEAR TAPER. THOSE MARKED 2W ARE OHMITE TYPE "AS" OR EQUIVALENT.

T-1, T-2, T-3, T-4, STANCOR TRANSFORMER TYPE A-53, (1-3 INTERSTAGE).

THE F-8 DIODES USED IN THE MAIN POWER SUPPLY ARE MADE BY SARKS-TARZIAN. THEY ARE 800PIV, 500MA SILICON DIODES.

A MARK, B MARK, A SPACE, B SPACE, SPARE POSITIONS PROVIDED FOR SPECIAL 3-POLE BUTTERWORTH MARK AND SPACE CHANNEL FILTERS. SEE SEPTEMBER 1966 "QST" FOR DETAILS.

SWITCH S-9, THE ANTI-SPACE ON-OFF SWITCH, IS FOR TEST PURPOSES ONLY AND MAY THEREFORE BE MOUNTED ON THE REAR PANEL RATHER THAN THE FRONT SINCE IT IS NOT NORMALLY USED. SEE TEXT FOR DETAILS.

THE 5.0 VAC WINDING OF THE MAIN POWER TRANSFORMER IS NOT USED. IT IS SPARE FOR POSSIBLE FUTURE USE.

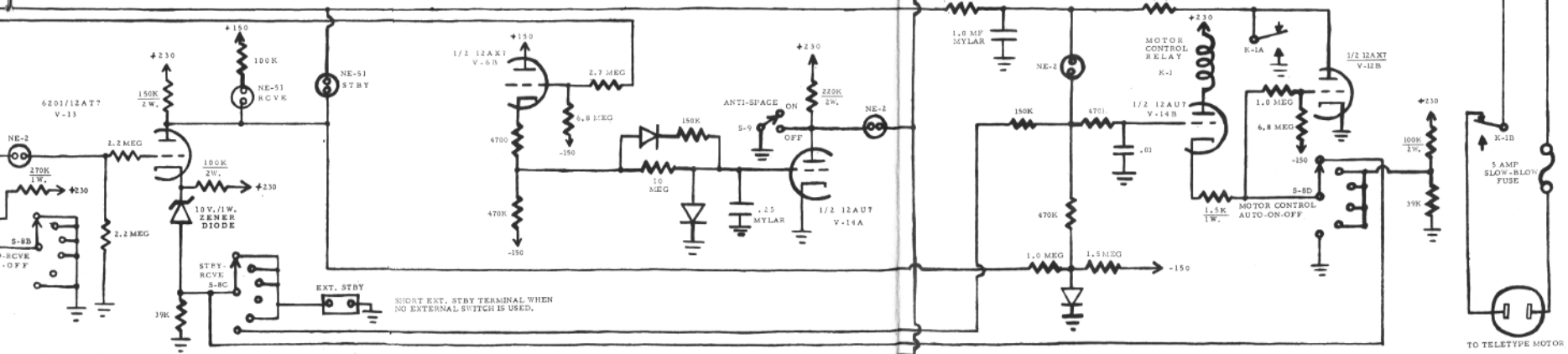

MAINLINE TTL-2 FSK DEMODULATOR  
 DESIGN W8SDZ DRAWING W8DLT & W8SDZ PUBLISHED RTTY JOURNAL 9/67



printer circuit boards; and to those who tried the new circuits during the development of the TT/L-2.

Special thanks go to my wife, Bev, for her help and understanding.

\*\*\*

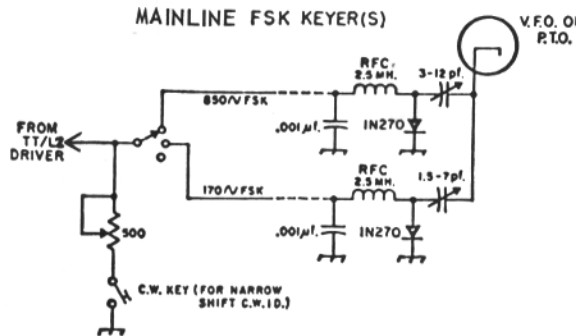

\*\*\*

### FSK Keying circuit for 100V and TT/L Demodulator..

Those using the popular TT/L demodulator keying circuit on a 100V exciter will find they are upside down unless a polar relay is used. This can be cured in a simple way by changing the keying circuit. This consists of using a 25K 4 W potentiometer as shown and adjusting until the voltage at the FSK jack is equal on mark and space. The 1K 20W resistor is interchanged with the keyboard and magnets. This will provide correct polarity. A switch to open the FSK line on receive is recommended as sometimes poor printing will occur otherwise. The same switch can often be used to turn on the transmitter by using a 2 pole or more of some type.

\*\*\*

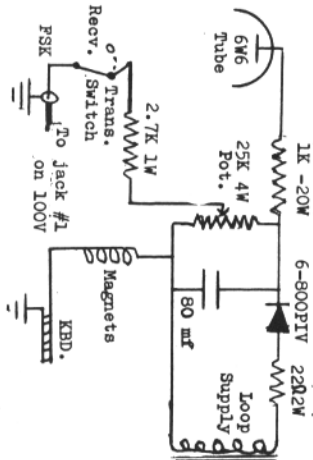

### Transistor Interval Timer

Here is an interesting circuit that might be of use to RTTY fans looking for an interval timer for those ten minute intervals. With the proper relay a variety of optional operations could be performed such as a warning light, an auto-matic CW machine activated, printer shut off or you name it. We have borrowed this circuit from the "Fresno Skip" with Roy, K6KOL the author.

### RTTY Net Operation

The Auto-Start net that has been operating on 7137.5 during the summer has now moved back to the regular 80 meter frequency of 3637.5, 170 shift.

We will be glad to have information of any other nets that are operating again.

\*\*\*

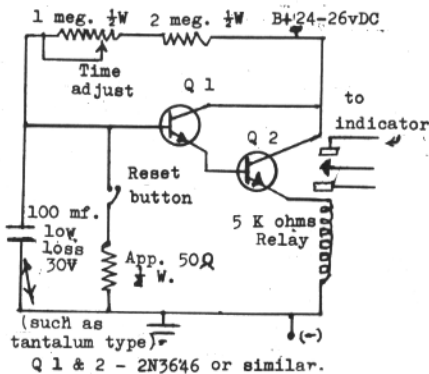

Transistor Interval Timer  
RTTY JOURNAL

# VHF RTTY NEWS

RON GUENTZLER, W8BBB Editor

Route 1, Box 30  
Ada, Ohio 45810



### SIMPLE TESTING PROCEDURES

We are going to describe some simple, but effective, testing procedures that can be applied to keyers and terminal units (demodulators). These tests are valuable for keeping the equipment in a station properly adjusted as well as for comparing the performance of different pieces of equipment.

These procedures will be described specifically for use with AFSK keyers and audio-type terminal units; however, some of the principles can be used with FSK keyers and IF-type T.U.'s.

The amount of testing equipment needed will depend upon the thoroughness desired. We have found that the following equipment is minimal: An average - or true rms-reading AC VTVM, a good milliammeter for measuring loop current, an oscilloscope, and a dot source. An excellent average-reading AC VTVM is the Heath IM-21, slightly modified (we will be glad to supply the modification instructions, upon request); of course, an AC VTVM such as the H-P 400- series is satisfactory. The dot source is a simple 22 Hz square-wave generator with metallic contacts, or the equivalent, in the output; the I-193-C Polar Relay Test Set is an excellent source of "60-speed" (22 Hz) square waves. It is described in our article: "The I-193-C Polar Research Test Set and Dot Generator", RTTY, April, 1965, pp. 5-8. In last month's "column": "An AFSK Keyer", we described a keyer ideally suited for testing T.U.'s (as well as for on the air use).

### Checking the Dot Source

If the I-193-C Test Set is to be used, check for zero bias by means of the internal calibration procedure described in the Technical Manual. If "dry" keying is used in your station, remove the filter in series with the output jacks.

Place a milliammeter in the keying loop and note the current reading. Insert the dot source into the keying loop and note the milliammeter reading while the

dot source is operating. The milliammeter should read exactly one-half the amount of current indicated before the dot source was introduced. If it does not, bias is present and no further tests should be made until the source of bias is discovered and eliminated. (If selector magnets are present in the loop, they will introduce spacing bias, and, if they are normally present during RTTY operation, the bias will have to be compensated in the keyer.)

One note on the "one-half" reading of the milliammeter: because the keying rate is relatively low, the meter damping will probably be such that the meter will appear to hover or vibrate about a point on the scale that is one-half the original reading; this hovering is normal. However, if the point at which it hovers tends to erratically jump around or "jitter", there is trouble in the keying circuit.

If "dry" keying is being used, the bias and jitter can be checked by placing an ohmmeter across the dot source output. The ohmmeter should read zero ohms when the dot source is turned off. When operating, the ohmmeter should read half-scale. Again, the meter may hover rather than sit perfectly still, but there should be no jitter.

### Checking the Keyer

Once the dot source has been checked out, connect it to the keyer input. Connect the keyer output to the transmitter input and place an oscilloscope across the audio pair. Turn on the dot source and adjust the oscilloscope to show one mark and one space element (a sweep rate of approximately 22 Hz). (This is one place where the dot source is superior to a character generator; with a character generator it is necessary to show a complete character composed of 7 elements, whereas with a dot source only two elements are necessary.) Keying transients, if present, will show up at this point.

Read just the sweep rate on the oscilloscope so that the mark and space elements overlap. (A sweep rate of approxi-



mately 45 Hz.) If they overlap perfectly, there is no bias at this point. If there was bias in the keying loop due to selector magnets and there is bias at this point, either adjust the keyer or do something in the keyer loop to get rid of the bias. In the keyer we discussed last month, R8 can be adjusted to decrease output bias resulting from selector magnets in the keyer loop.

#### T.U. Bias and Jitter Tests

Connect the output of the keyer to the input of the terminal unit. Also connect the AC VTVM across the terminal unit input. Adjust the keyer mark and space levels so that they are equal and at the level normally used when receiving a RTTY signal from the receiver. Connect the output of the terminal unit to a loop containing no selector magnets or other inductive devices. Place the milliammeter in this loop and adjust the loop current to the level normally used when operating the teleprinter. (This test can be performed using the meter in the I-193-C Test Set if the T.U. output has relay contacts and the I-193-C has been modified per our April 1965 article.)

Apply the dot source to the keyer and note the loop current meter. It should be at a value one-half the normal loop current. If it is not, the terminal unit is introducing bias; if there is bias, read just the T.U. until the bias disappears. Also, note whether or not any jitter is present; if there is jitter, it can either be from troubles in the keyer or the T.U.

With everything operating, and no bias in the output of the T.U., change the level of the audio into the T.U. and note any bias in the output loop. This test will indicate the dynamic range of the T.U. when supplied from a noise-free signal containing mark and space tones of equal level.

#### T.U. Mark or Space Only Tests

With the test equipment still operating, set the level to what appears to be a desirable level consistent with normal operating procedure at your station. Now slowly decrease the space tone leaving the mark tone unchanged and note the effect upon output bias. Return the space tone to its original level and decrease the mark tone. If your T.U. is equipped with "Mark Only" or "Space Only" circuitry, these tests will show how well the circuitry actually works. (For AFSK work, these tests may not be necessary, but they are mandatory for FSK work.)

#### T.U. Noise Performance Tests

The following terminal unit tests will require some observation of normal operating conditions before they can be performed. Also, because they will require a printer, the tests will be dependent upon adjustment of the printer and will, in general, be valid only when using that printer.

Place an AC VTVM across the input terminals of the T.U. and observe the relative mark and space levels received during normal operating conditions. For example, at our location the space level is usually about 5 db below mark and mark is normally in the range from -4 to +2 dbm, but can vary from -10 to +6 dbm depending upon the deviation of the transmitting station.

Connect a source of RTTY characters to the keyer input. The best sources are the 100-A Test Set and the TG-2/B "Brown Fox" generator. It is possible to use a keyboard, but the keyboard should be known to be properly adjusted. The output of the station receiver, the output of the keyer, the input of the terminal unit, and an AC VTVM should be connected in parallel. If these units do not all have approximately the same output/input impedances, you are shot down. If you are using an AM receiver, turn the AF gain control to zero; if you are using an FM receiver, close the squelch. Connect the selector magnets of the teleprinter to the output of the T.U. Adjust the output levels of the keyer so that they are representative of the levels normally fed from the receiver into the T.U. For example, we would set Mark to 0 dbm and Space to -5 dbm at the input terminals of the T.U. Send a test message from the signal source (a repeated character from the 100-A, "Brown Fox" from the TG-2/b, or "RY" from the keyboard). The printer should be receiving properly. Introduce noise by running up the gain controls on the AM receiver or open the squelch on the FM receiver. Set the noise level to that normally experienced on weak signal reception. The printer should be able to copy perfectly. Now slowly decrease both the mark and space levels coming from the keyer, keeping the relative values the same; i.e., if Space was 5 db below Mark, keep it always 5 db below Mark. When the point is reached where the printer starts to make mistakes, increase the output from the keyer until the mistakes just disappear. Measure the noise and signal levels separately without disconnecting anything. One possible method

for making this measurement is to note the total signal - noise level and then remove the noise by turning down the RF gain control on an AM receiver or by closing the squelch on an FM receiver. With the noise removed, the signal level can be measured. If the signal level is 10 db or more below the combined signal + noise level, the noise level is approximately equal to the signal + noise level. If the AC VTVM is a true-rms meter (very few are, even though the meter face is labeled "RMS VOLTS"), the performance is established. If the AC VTVM is an average-reading meter, such as the Heath IM-21, there is about a 1 db error introduced. (This 1 db error will always be present so that relative measurements are valid when comparing various T.U.'s.) If the meter is one of the more-or-less-common combined AC, DC, Ohms VTVM, it is probably peak-reading so forget the whole thing!

Once the performance has been established, it is possible to seek improvements in T.U. performance by making adjustments in the T.U. at signal-to-noise ratios where errors appear. After such adjustments have been made the performance should be checked as done in the previous tests to make sure that bias has not been introduced. Also, if you want to compare the performance of several T.U.'s, they can be compared for noisy signal performance in the manner just described.

Again, remember that the results are dependent upon your teleprinter and therefore are valid for your station but not necessarily for other stations. Also, the spectral noise components are dependent upon the receiver.

#### An Additional Note

The T.U. Noise Performance tests provide a means for making a carefully-controlled source of "weak signals". Not only do you get "weak signals" when you want them, but also you can control and measure these signals. This should be a great aid when adjusting a T.U. Also, when designing a new T.U., it is possible to compare your new "Super T.U." with one on hand. This will provide more definitive tests than "off-the-air" signals.

#### Overall Tests

Another test that can be made involves sending dots into the keyer and measuring the jitter and bias from the T.U. when the keyer is connected to the transmitter and you are on the air.

#### Last Month's Keyer

Last month we mentioned that some of the 2N3820 J-FET's would not oscillate. A crude, but acceptable, analysis of the circuit reveals that the criterion for oscillation requires  $y_f \neq y_{os}$ . If some other transistor type is to be used, select one that has  $y_f$  greater than  $y_{os}$ .

#### So What's New?

Not much. We have received no news from anyone out there in RTTY-Land!

We have moved, but have not been able to get on the air yet.

\* \* \* 73, RG

#### Automatic Carriage Return

for Model 15.19

#### FEATURING:

- o SELF CONTAINED WITHIN PRINTER UNIT AVOIDING LINKAGE DISCONNECTING WHEN REMOVING PRINTER.
- o CONVENIENT CHANGEOVER FROM AUTOMATIC TO NORMAL OPERATION AT THE FLICK OF A SWITCH.
- o AUTOMATIC CARRIAGE RETURN ON 73rd CHARACTER TO PREVENT LITTLE "BLACK THINGS" AT THE END OF THE LINE WHEN THE NORMAL CARRIAGE RETURN IS NOT RECEIVED.
- o LINE FEED AUTOMATICALLY WHENEVER CARRIAGE RETURN IS ACTIVATED EITHER NORMALLY OR FALSELY TO PREVENT OVERPRINTING.
- o AUTOMATIC REJECTION OF EXTRA LINE FEED SIGNALS TO PREVENT WASTING OF PAPER. (WHEN CARRIAGE IS IN FIRST CHARACTER POSITION)

Anyone looking for a good, sure, way to install an automatic carriage return, line feed, might write K8JTT for his drawings and instructions. We would like to publish them but the drawings are made full size for easy construction and fill seven letter size pages so we just can't find the room. Ev, K8JTT has some extra copies in Xerox and for a buck, to cover the cost will send anyone a set of prints. They are for a 15 or 19 machine and for our money an automatic carriage return and line feed is the best thing anyone can add to a machine.

\* \* \*

# RTTY-DX

JOHN POSSEHL W3KDF Editor

P.O. Box 73 Blue Bell, Penn. 19422



Hello there. . .

Just finished a nice three way QSO with Dusty, and Pete, K8YEK and during the course of the conversation Dusty subtly asked if I had mailed him this months copy yet. Upon receiving a negative answer he promptly said that I was pounding away on the wrong typewriter and that I had better get cracking on the Underwood. By gosh, he's right, it is that time of the month again, so here we go.

John, KL7DRZ sends along some information on his location and activities that I'm sure will be of interest to all. John is located at Auke Bay, some ten miles north of Juneau. He is blocked to the South by a 4000 foot mountain and as a result finds it nearly impossible to get into the states at all. As a result most of his contacts have been over the Pole into Europe in one direction, and to the South Pacific and Antarctica in the opposite direction. Of particular interest is John's antenna system. This is a sixteen element twenty meter array suspended between two one hundred foot trees. It consists of 4 driven elements, 4 reflectors, and 8 directors. It must be extremely effective in its desired directions too, as John maintains daily schedules with KC4USB. This is quite an accomplishment as at this time of the year the MUF in the South Pole region is only about 6 mc. and to get out on a higher frequency it is necessary for the KC4 boys to beam a signal at the ionosphere a thousand or so miles away, line of sight, to prevent absorption of the signal. John also tells of the narrow shift experiments he conducts with Bob, ON4CK. Down to 20 cycles and real copy-able.

Jose, PJ2MI recently indicated that there were two good possibilities for activity from Curacao. Jose has a new Model 19 and when he gets it set up he will send some of his present gear to PJ2CZ. PJ2CR was on a trip to the states and was expected to bring back a machine. This has apparently come to pass because just the other day I printed Jose sending test tapes to PJ2CR. By the time you read this Cur-

## RTTY DX HONOR ROLL

	Countries worked	Countries confirmed
1. FG7XT	74	60
2. ON4BX	59	53
3. W3KDF	59	53
4. I1KG	62	49
5. W6CG	51	46
6. W8CQ	50	43
7. K8YEK	52	42
8. VE3AYL	48	40
9. W1GKJ	40	36
10. UA1KBW	36	33
11. W3ISE	33	28
12. VE4BJ	28	28
13. WA8BOT	32	26
14. K8JTT	30	24
15. W8CAT	26	23
16. K8QLO	37	22
17. KL7BAJ	26	22
18. WB6ADY	24	20
19. VP9BY	26	18
20. K9QNV	24	17
21. OA4BR	22	15
22. W6LDA	23	13
23. W4FUI	33	11
24. FG7XT/FS7	9	9
	(4-27 to 5-6 1965)	
25. K6YUI	8	7

The next listing of the DX - HONOR ROLL will appear in the DECEMBER issue. Please have your totals to me by the 1st of NOVEMBER if they are to be included.

acao may already be on as a new country. Newt, K8QLO reports YN4NN in QSO with DL0IB. Nicaragua is certainly a rare one and lets hope that he continues to be active.

Fred from HK3SO continues to be quite active giving many of the boys a new country.

Dusty reports that there may be a possibility of activity from Bolivia. This would be in addition to CP1BX who has not been active the past several months.

Zip, OA4BR has been in the States on vacation but is now back in Lima with his usual fine signal. We have worked out an

RTTY JOURNAL

arrangement whereby I will act as Zips QSL manager. So if you send your cards through me, I will verify the contact and send one in return. A self addressed stamped envelope is requested.

While on the subject of QSL'S, Jean, FG7XT reports that cards from Alban, 5T5AD are coming through via the bureau. Jean also asks if anyone has QSL information on Terry, 5X5FS. Jean further indicates that he hopes to operate again from FS7 before the end of the year.

A few months ago we said that perhaps there would be activity from a couple of the boys in the Canal Zone. Well, just recently, Mike KZ5GA has come on the band with a real strong signal. He was having some shift problems which should be squared away by this time.

I was very happy recently to have had a contact with Mr. RTTY himself; our old friend, W6AEE. Merrill says he has not been too active lately due to the demands of work but as the pressure eases off he hopes to be on the bands more often for some rag chewing with old friends.

Unfortunately, we must also extend our condolence to two of our readers. It seems that Warren, W3ISE, and Newt, K8QLO each have a broken foot. Well fellows, I could have told you that these RTTY machines are quite unyielding when kicked. I had a broken foot myself a year or so ago to prove it. It's a good opportunity to catch up on your DXing though.

From across the pond we have a few interesting items from Arthur, ON4BX. First Arthur reports the operation of LX2BQ who has now been on RTTY for a few weeks. The operator is Willy and he is the brother-in-law to Bob, ON4CK. It would follow that Bob was instrumental in getting this new station on from Luxembourg. I understand this is not a DXpediton so we should all have an opportunity to contact this rare prefix.

Arthur has also been in contact with VU2KX via the mails and also on a C.W. schedule. Apparently Venkat is all ready to go but was still lacking the authority to use F - 1. Since this contact with Arthur however, Dusty has informed me that the Calcutta station now has the necessary permission and is putting up a Quad to replace the present dipole in order to put out a better signal. It certainly might be worthwhile to listen at the appropriate time for VU in your area and perhaps get this really rare prefix.

Now that the cooler weather and contest

RTTY JOURNAL

months are approaching, I would like to bring you up to date on the activities of Cas, KA9AK. As you know, Cas really had 10 meters jumping last Winter and Spring but with the coming of the warmer weather 10 meters all but faded out for long haul DX. Cas is still very active however, and constantly improving his station. If you operate 20 meter c.w. you may run across him from 1000 to 1500z most any day.

Cas plans to start monitoring 29mc. again in earnest beginning about the 15th September and in fact will start checking the band from time to time beginning 1 September from 2200 to 2215z daily and from 2200 to 2300z on week ends. He will sweep the frequency from 29.0 to 29.040. Cas suggests that if you have taps gear you send "quick brown foxes" at few minute intervals. The thing to remember is that Cas will not be sending CQ or testing but he will be listening. So the chances are that if you make some noise up there and conditions are favorable it is a good bet that Cas will hear you and give you a call. Cas will be there until next June and has already tried to get some other fellows in RTTY including a Japanese national (JA8SZ) but without success so far. At the risk of repeating myself and for those who may be wondering why all this importance about 10 meters it must be remembered that Japan does not permit RTTY below 29 mc. Incidentally, Cas says that he had more contacts above 29 mc. with mobile A.M. stations during the last band openings than he did with RTTY stations. If those guys can do it with their 12 volt power supplies, I guess we should make it handily.

The other day, Howie, KR6FQ, was heard in these parts at high noon on twenty meters. Now thats one for the books. Maybe conditions are changing for the better.

I hope that you are all preparing for the big contest. It comes up next month and that isn't very far away anymore. I guess that we will have one more opportunity to get together before then though. I'll try to keep close watch on the bands and let you know what is going on just before the Contest.

Well, that finishes the rough draft of the column. Now I better see how this thing fits on the Underwood, cause Dusty is waiting at the mailbox.

\* \* \*

73 de John



This issue containing 6 extra pages is a little extra bonus for the wonderful support from our readers and authors. We would like to enlarge the Journal but the postage situation makes this difficult as one page over the regular size doubles the postage cost. 2nd Class mailing could help this problem stateside but with several hundred foreign air mail subscribers the extra weight would make the cost prohibitive. Even now the rate to Europe is 40¢ a copy. So for the present, we will go along "as is" and see what develops.

In case you are confused - last month - July-August was the combined summer issue. We hope to get this issue in the mail about the 20th of the month and future issues the same date. Notice that the deadline is now the 1st of the month for all copy and ads.

The back issue situation, (we continually get inquiries) copies from, May through December, 1966, March, April, May and June of 1967 only, at 30¢ each.

Freeman, KH6AX and his bride Diana celebrated their 15th wedding anniversary (months) with a trip through the South Pacific. Samoa, Tahiti es all. Wonder if Freeman took pictures for an even better QSL. (Have you seen his old one?)

On August 10th the wire services carried a report that the FCC was about to act on the incentive license plan within weeks. No mention of what action would be taken but hints of a lot of changes.

Peter, K8YEK, has acquired oertificate #1 for "Worked all States" given by the RTTY Bulletin of Florida. This certificate has been available for a long time but Peter is the first to qualify. With activity available in all states lets see how many more can qualify for a Worked all States award. The ARRL issue one endorsed for RTTY also. So far we haven't heard of anyone that has qualified except K8YEK.

The best laid plans of mice and men-- so we are about a week later with this issue than our original plans but feel the slight delay was worth while. Because of the delay we will accept classified and other information until the 5th of next month but there after will be the 1st of the month.

Bless their hearts, W8IS and WA3CFK finally broke the ice and sent us some 'Hints & Kinks'. Maybe somebody else has some little idea and will add to our collection. Next month we will try to run a few of them.

Most of the authors in the Journal will answer questions on their specialty but be as specific as possible on questions. A self addressed, stamped envelope, is a courtesy that should always accompany any request.

While most nets are primarily used for traffic, general news and information is also exchanged. Newcomers are always welcome so break in - get you feet wet.

### Coming Soon.

We have several more of the articles by Irv Hoff, W6FCC, on using Collins receivers on RTTY. The KWM tranceiver is scheduled as soon as we have room to run in one issue. As a rule we dislike running an article in two parts.

## RTTY JOURNAL

P.O. Box 837 - Royal Oak, Michigan 48068

"Dusty" Dunn - W8CQ

Editor & Publisher

SUBSCRIPTION - 1 Year (11 Issues)

U.S.- Possessions - Canada-Mexico

First Class -\$3.00

Air Mail -\$3.50

South-Central America - \$5.00

All Foreign Countries-

First Class -\$3.50

Air Mail -\$5.50

FOR SALE- WHEATSTONE OILED 15/32 perf tape for CW Boehme keying heads. Any quantity. P.L. Lemon, W6DOU, 3154 Stony Point Rd. Santa Rosa, Cal. 95401.

FOR SALE - Two Tone Transistor Demodulator as described in cover article June RTTY JOURNAL 1967-glass-epoxy PC board, drilled, \$8.00 postpaid with all instructions for building and adjusting. Cashion Electronics, P.O. Box 7307, Phoenix, Ariz. 85011.

TYPEWRITER RIBBON REINKER, Hand operated model now only \$3.00. K575 or K764 Ink available at all National Cash Register Co. stores at 75¢ per tube. Walter Nettles W7ARS-8355 Tanque Verde Rd. Tucson, Ariz. 85715.

SERVICE-BUY-SELL, RTTY - Cleaning and repair of Teletype machines. Have in stock every part for model 14, 15, 19, and many parts for 12, 26, 28, 32, 33, 35. Teletype machines all models, in any stype, and all special features available. Will buy, trade or sell teletype parts and machines. 88 mhy toroids 5 for \$1.50 postpaid. Call or write, Martin Geisler, 8926 Kester Ave., Van Nuys, Calif., 91402 - Phone (213) 892-0685

TUNABLE FREQUENCY CONVERTERS. Continuous tuning of shift from 100 to 900 Hz. allows tuning of non-standard shifts, allows instant changing from wide shift to narrow shift and vice-versa. Tuning lights give fast, positive indication of signal being tuned in. 250Hz @ 6DB selectivity each channel. Built in loop supply adjustable 20 to 120 MA. Metering circuit shows loop current and mark/space state. Built in band pass filter. All solidstate. 20 semi-conductors and 1 integrated circuit. No converter on the market can match the Pioneer 900. Price \$189.50 wired and tested. Guaranteed for one full year. Write to Pioneer Electronics, 738 Pacific St. San Luis Obispo, Calif. 93401.

FOR SALE: 2125 and 2975 CPS dual tuning fork assembly \$33.00, .05% stability, 68 to 86 degrees F. Transistor fork drive circuit kit, \$10.00, assembled circuit \$16.00. Data available Riverbank Laboratories, Box 65, Geneva, Ill. 60134.

Plug in networks, Northern Radio type 153Z, No. 10 or No. 14, these are interchangeable with Northern Radio converter 152 model 2. Northern Radio Tone Keyer 153 and Frequency Shift Tone Keyer and converter 164, unused \$7.50 each. Polar Relays 255, \$1.25 each. Min. order \$5.00. Three headed T.D.s with synchrous motor \$40.00. Frequency Shift Keyer Northern Radio type 105, Model 4A with power supply \$75.00 each. Atlantic Surplus Sales, 250 Columbia St., Brooklyn, N.Y. 11231

COLLINS 51J4- Like new, original purchased from Collins, not surplus, I.4--3.1--6.0KC mechanical filters. \$975. Electrocom TK-100 Tone keyer, like new, \$35.00. H.C. Anderson, K8NZD, 1441 Lenox Rd. Bloomfield Hills, Mich. 48013.

BUY - 28 TYPING units, etc., and all parts. Sell 14s 15s 28KSR. (28ASR) parts. W4NYF, 405 NW 30th Ter., Ft. Lauderdale, Fla. 33311. phone 305-583-1340 after 9.

WANTED - Teletype Parts for all machines. Models 14, 15, 19, and 28 etc. Must be new in Teletype Corp. pack or military with 5815FSC ....Phil, K2HJC, Box 96, Morrisonville, New York 12962.

RTTY GEAR for sale. List issued monthly. 88 or 44 mhy toroids 5 for \$1.75 postpaid. Elliott Buchanan W6VPC, 1067 Mandana Blvd., Oakland, Calif. 94610.

PRINTED CIRCUIT BOARD, TT/L2 with schematic, pictorial, voltage chart and construction tips: \$6.00; Precision Tuning Fork 400 hz. with electronics less 2-6AU6, small pwr. supply, modify to 425hz: \$5.00; standard 44 or 88 mhy. toroids, unpotted: 5/\$2.00 pp. USA; special larger, low resistance 88mhy. toroids, 1.5": 50¢ each; teletype test tape, either 11/16 punched paper or 1/4 inch magnetic AFSK (3.75ips) runs 7 min.: \$2.00, all items above postpaid in USA. K5BQA, 11040 Creekmore, Dallas, Texas, 75218.

TT63A REGENERATIVE REPEATER complete with tubes, cable, instructions and schematic - like new \$20. each. RTTY Dual frequencyshift tone converter, Northern Radio type 152, each tone converter is self contained with power supply, conversion details and schematic included, used good condition \$20.00 each. Model 14 TD with synchronous motor - used - good - \$25.00 each. Squelch Adaptor Modification kit used on Hammarlund radio receivers, SP600 kit includes adaptor unit, name plate, knob, skirt assembly, tubes and cable clamps, new \$7.00 each. We buy and sell parts. Write us. . .Atlantic Surplus, 250 Columbia St., Brooklyn, N.Y. 11231

TOROIDS, 88mhy. center-tapped, unpotted, 5/\$1.50 POSTPAID. Model 15 machine, new \$75. Northern Radio 104 converter. \$30. Heath VF-1 VFO \$10. Gears for all speeds. write. Drake lo-pass filter, 1KW. \$7.50 Page printer paper \$5.50/case. Like new Johnson 250-23 Matchbox. . . \$65. Sync motors. \$10. Unconverted 522 transmitter. \$15. HQ-140XC \$105. Simpson 260 (brand new) VOM \$40. Valiant \$130. WANTED: Rotator, audio oscillator. capacitor decade, two meter communicator, tri-band beam. 6 meter halo. SX-28 receiver, Clegg 99er. Will trade. . .Stamp for list. . . W2DLT 302 Passaic Stirling, N.J. 07980

WANTED, RTTY JOURNAL for January 1967 to complete collection, also Technical manual for Western Union Model 103 Tele-Printer, WA3CFK, 118 Overhill Dr., Hagerstown, Myd. 21740

\* Dual 500 mfd. @ 25 volts, FP cantype mtg, hook together for 1000 mfd. 35¢ each or 10 for \$2.50 plus postage. A.R.C. Sales, PO Box 12. Worthington, Ohio, 43085.

WANTED - MANUAL covering the Model 15. Please state price including postage. K2MOO A.S. Cooke, 21 St. Paul's Ct. Brooklyn, N.Y. 11226

WANTED; To buy or borrow, TM11-2210 and/or TM11-2211. K6MBH. 413- 43rd Ave. San Francisco, Calif. 94121

ELECTRONICS WORLD WANTED - August 1961 Issue. W6BWQ, 6449 Graves Ave. Van Nuys, Calif. 91406