

17 R.H.

R-391 DL 1890 00-

NOTICE: When Government drawings, specifications, or other data are used for any purpose other than in connection with a definitely related Government procurement operation, the United States Government thereby incurs no responsibility or any obligation whatsoever and the fact that the Government may have formulated, furnished, or in any way supplied the said drawings, specifications, or other data is not to be regarded by implication or otherwise as in any manner licensing the holder or any other person or corporation, or conveying any rights or permission to manufacture, use or sell any patented invention that may in any way be related thereto.

NEXT ASSEMBLY	USED ON	SWE. * APPROVAL	REVISIONS			
			SYM	DESCRIPTION	DATE	APPROVAL
SM-B-178949	SC-DL-178467	S Y 10442-5	A <sub>3</sub>	A <sub>1</sub> -562 WAS .437; A <sub>2</sub> -WAS AN-S-771 & FM.	9 OCT. 59	42428-PC-59-A1-51 REV'D.
SM-B-178959	SC-DL-248775			A <sub>3</sub> -ADDED APPL. SM-B-178959, SM-B-248944, SC-DL-248775;		
SM-B-248944						
		CA B 84528	B	B <sub>1</sub> -SYMBOL Δ WAS * 4 PLACES.	24 DEC. 59	42428-PC-59 REV'D. PNE

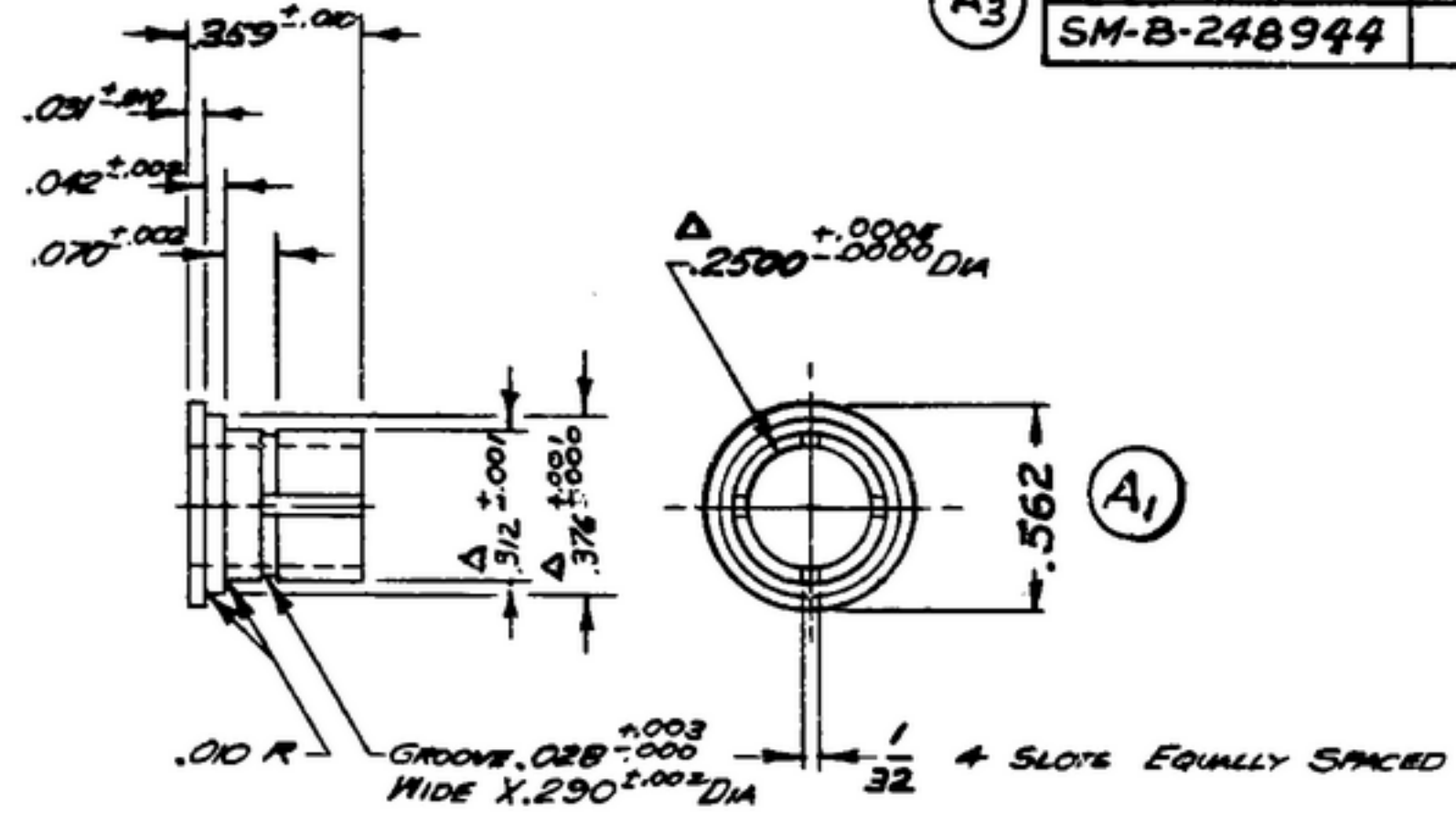

**A<sub>2</sub>**  
STEEL, COMP 3035 COND B, PER SPEC MIL-S-7720. **A<sub>2</sub>**  
1-SLIGHT BURRS PERMISSIBLE IN 1/32 SLOTS - ALL OTHER BURRS TO BE REMOVED.  
**B<sub>1</sub>** 2-ECCENTRICITY BETWEEN DIAMETERS MARKED Δ MUST BE WITHIN .002 TIR.

NOTE:  
FOR INFORMATION ONLY,  
CONTRACTOR MAY AT HIS  
OPTION DEVIATE FROM  
THESE PROCESS DETAILS

UNLESS OTHERWISE SPECIFIED	AUTHENTICATION	DESCRIPTION	DATE	SCALE	REVISION
DIMENSIONS ARE IN INCHES TOLERANCES ON FRACTIONS ± 1/64 DECIMALS ± .005 ANGLES ± COMMERCIAL TOLERANCES APPLY TO STOCK SIZES ALL SURFACES ✓	DRAWN R1852-PR 50-93 TRACED PHOTO CHECKED K VERIFIED P.D.B.R. APPROVED P.D.B.R. REVIEWED P.M.E. DATE 23 JUN 53	HUB		2/1	
					DEPARTMENT OF THE ARMY SIGNAL CORPS ENGINEERING LABORATORIES FORT MONMOUTH NEW JERSEY SM-B-178950

WHEN REFERRING TO THIS DRAWING STATE DRAWING NO., APPLICABLE ISSUE SYMBOL AND DATE