

9253 B

NOTICE: WHEN GOVERNMENT DRAWINGS, SPECIFICATIONS, OR OTHER DATA ARE USED FOR ANY PURPOSE OTHER THAN IN CONNECTION WITH A SPECIFICALLY RELATED GOVERNMENT PROCUREMENT OPERATION, THE UNITED STATES GOVERNMENT THEREBY MOVES NO RESPONSIBILITY AND ANY OBLIGATION WHATSOEVER; AND THE FACT THAT THE GOVERNMENT MAY HAVE FORMULATED, FURNISHED, OR IN ANY WAY SUPPLIED THE SAID DRAWINGS, SPECIFICATIONS, OR OTHER DATA IS NOT TO BE REGARDED BY CONTRACTOR OR OTHERS AS IN ANY MANNER LIMITING THE RIGHTS OR ANY OTHER PERSON OR CORPORATION, OR CONFERRING ANY RIGHTS OR PRIVILEGES TO MANUFACTURE, USE, OR SELL ANY PATENTED INVENTION THAT MAY IN ANY WAY BE RELATED THEREOF.

THIS DOCUMENT HAS BEEN FURNISHED BY THE GOVERNMENT AND MAY BE REPRODUCED AND USED IN CONNECTION WITH ANY GOVERNMENT PROCUREMENT OR BARGAINING OPERATION.

*FOR INFORMATION ONLY. CONTRACTOR MAY AT HIS OPTION DEVIATE FROM THESE PROCESS DETAILS.

ORIG. ISSUE A		REVISIONS	16 AUG. 56
SYM	DESCRIPTION	DATE	APPROVAL

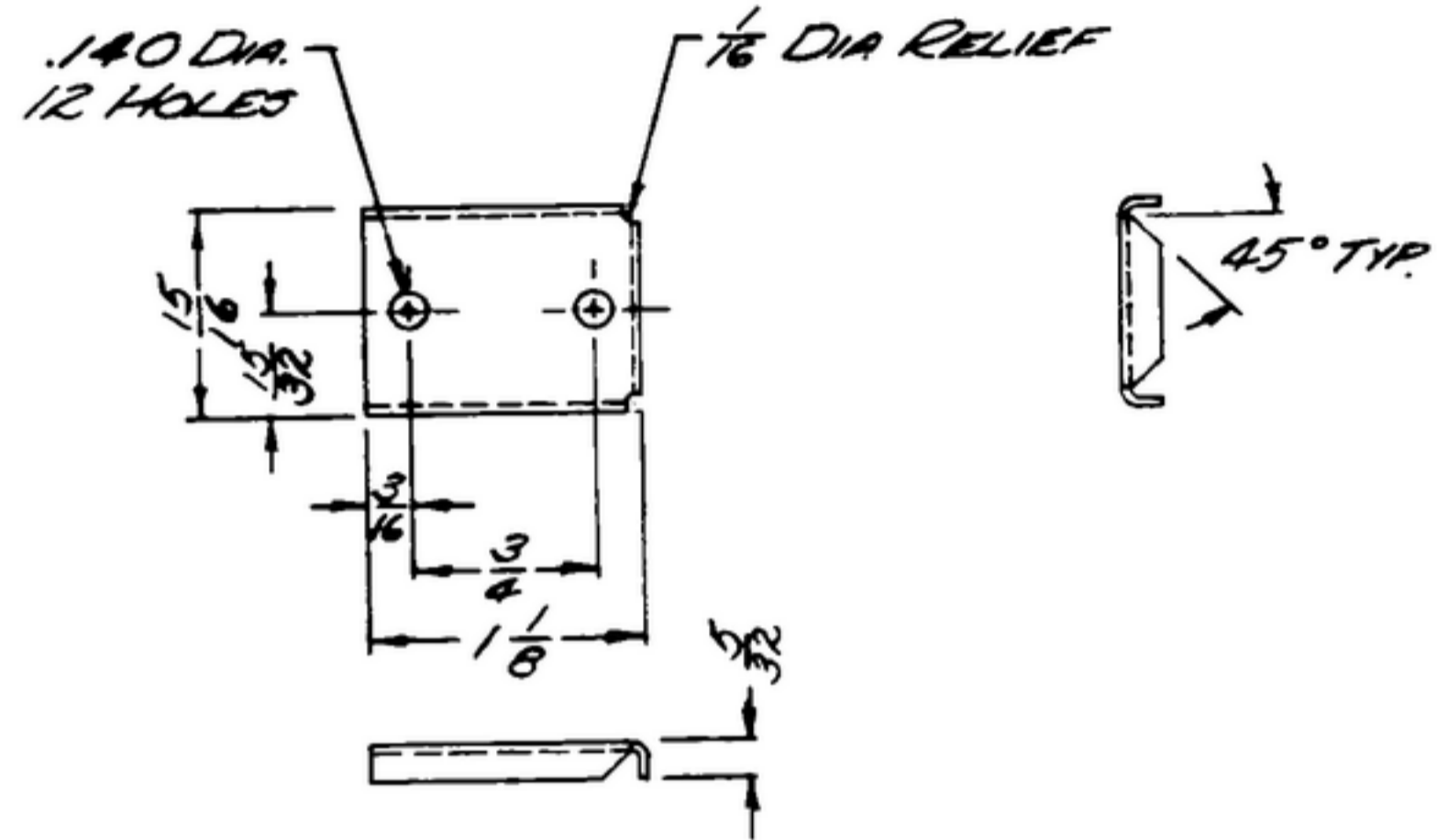

CRES TYPE 304 22 GA. USS (.031) PER SPEC QQ-S-766
CLASS 1, COND A.

NOTES
1. INSIDE BEND RADI SHALL NOT EXCEED METAL THICKNESS + 1/64.

	SC-GL-5775B
SMC-31965	SC-GL-57655
NEXT ASSY	USED ON
APPLICATION	

UNLESS OTHERWISE SPECIFIED
DIMENSIONS ARE IN INCHES
TOLERANCES ON
FRACTIONS DECIMALS ANGLES
± 1/64 — ± .25°

DET. NO.	REV.	PART NO.	DESCRIPTION	MATL.	FINISHED SIZE	QTY.	NOTE
LIST OF MATERIAL							
			BRACKET FOR POWER SUPPLY FOR INTERCHANGEABILITY GAGE FOR R-390A/URR AND R-392/URR	DEPARTMENT OF THE ARMY SIGNAL CORPS ENGINEERING LABORATORIES PORT MONMOUTH NEW JERSEY SM-B-31967			
			COLLINS RADIO CO. CEDAR RAPIDS, IA. Q8719-PH-55-93 SIGNAL CORPS REVIEWED XXX APPROVED R.F.A. DATE 21 AUG 56	SCALE 1/1	E300		

WHEN REFERRING TO THIS DRAWING STATE DRAWING NO., APPLICABLE ISSUE SYMBOL, IF ANY, AND DATE.