

506-2091-003-R-391

NOTE: ALL DIMENSIONS UNLESS OTHERWISE SPECIFIED ARE TO BE HONED TO THE CLOSEST TOLERANCE PER THE UNITED STATES GOVERNMENT STANDARD SPECIFICATION FOR HONED SURFACES. THE FACT THAT THE DIMENSIONS ARE HONED DOES NOT RELIEVE THE CONTRACTOR OF THE RESPONSIBILITY OF INSURING THE QUALITY OF THE HONED SURFACES. THE CONTRACTOR SHALL BE RESPONSIBLE FOR THE PROTECTION OF THE HONED SURFACES FROM DAMAGE DURING THE MANUFACTURING PROCESS. THE CONTRACTOR SHALL BE RESPONSIBLE FOR THE PROTECTION OF THE HONED SURFACES FROM DAMAGE DURING THE MANUFACTURING PROCESS.

NOTE: FOR INFORMATION ONLY, CONTRACTOR SHALL BE RESPONSIBLE FOR THE PROTECTION OF THE HONED SURFACES FROM DAMAGE DURING THE MANUFACTURING PROCESS.

SWE APPROVAL		REVISIONS			
SYM	PR	SYM	DESCRIPTION	DATE	APPROVAL
	PR10042-B	A <sub>3</sub>	A <sub>1</sub> - WAS, QQ-A-354; A <sub>2</sub> - ADDED FINISH NOTE; A <sub>3</sub> - ADDED APPL. SM-B-178665, SC-DL-248775.	27 OCT 59	42428-PC-57 -A1-S1 REV'D PME
	CA84855	B <sub>1</sub>	(1) .2510 DIA. WAS .2500 DIA.	14 SEP 60	42428-PC-59 REV'D PME
		C <sub>2</sub>	(1) MAT'L SPEC WAS QQ-A-354 (2) .2500 WAS .2510	23 MAR 1965	21582-PC-61 REV'D PME
		D	D <sub>1</sub> .2510 WAS .2500 ±.0005 D <sub>2</sub> .2510	26 MAY 66	6-0005 REV'D PME

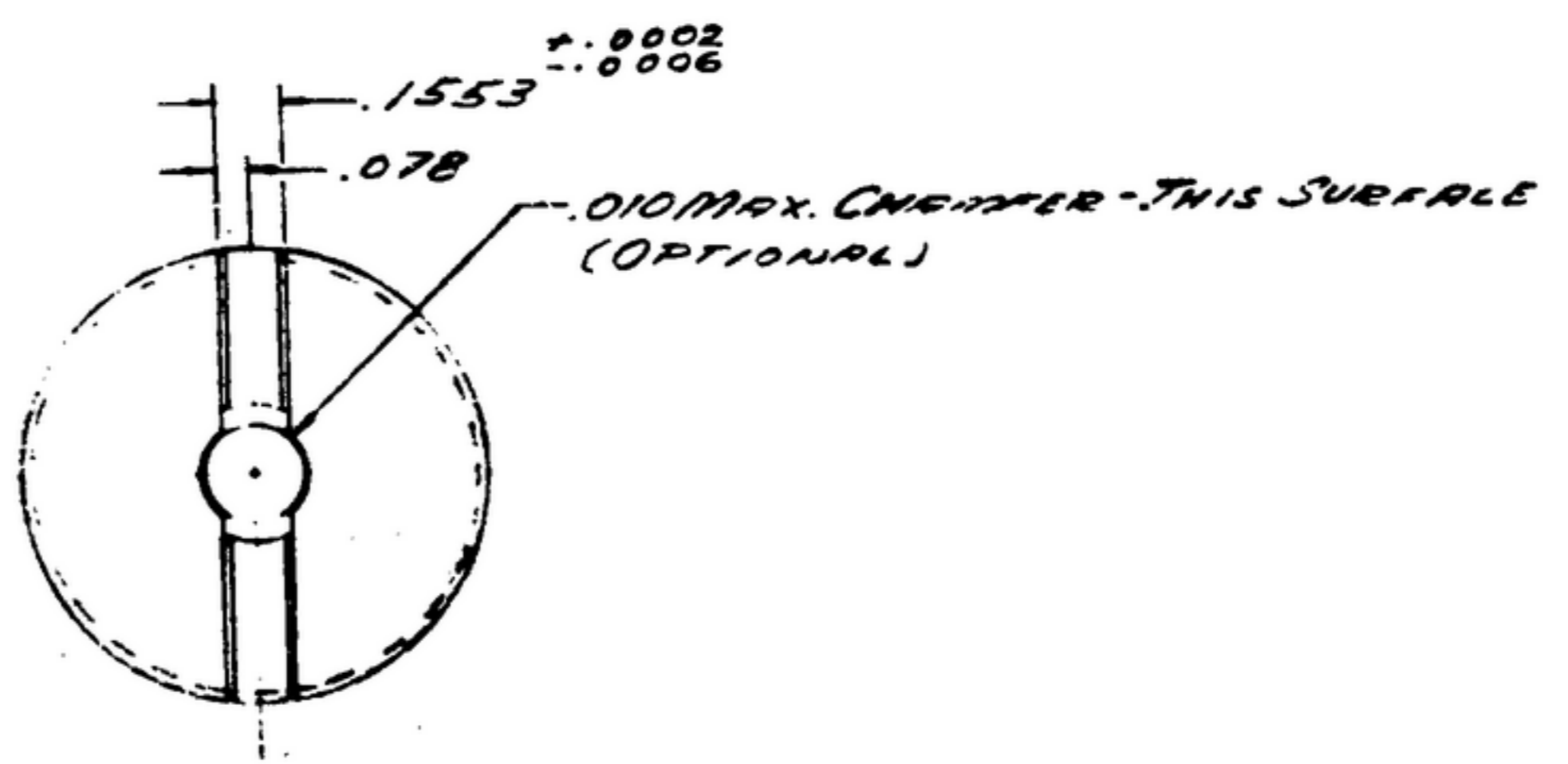
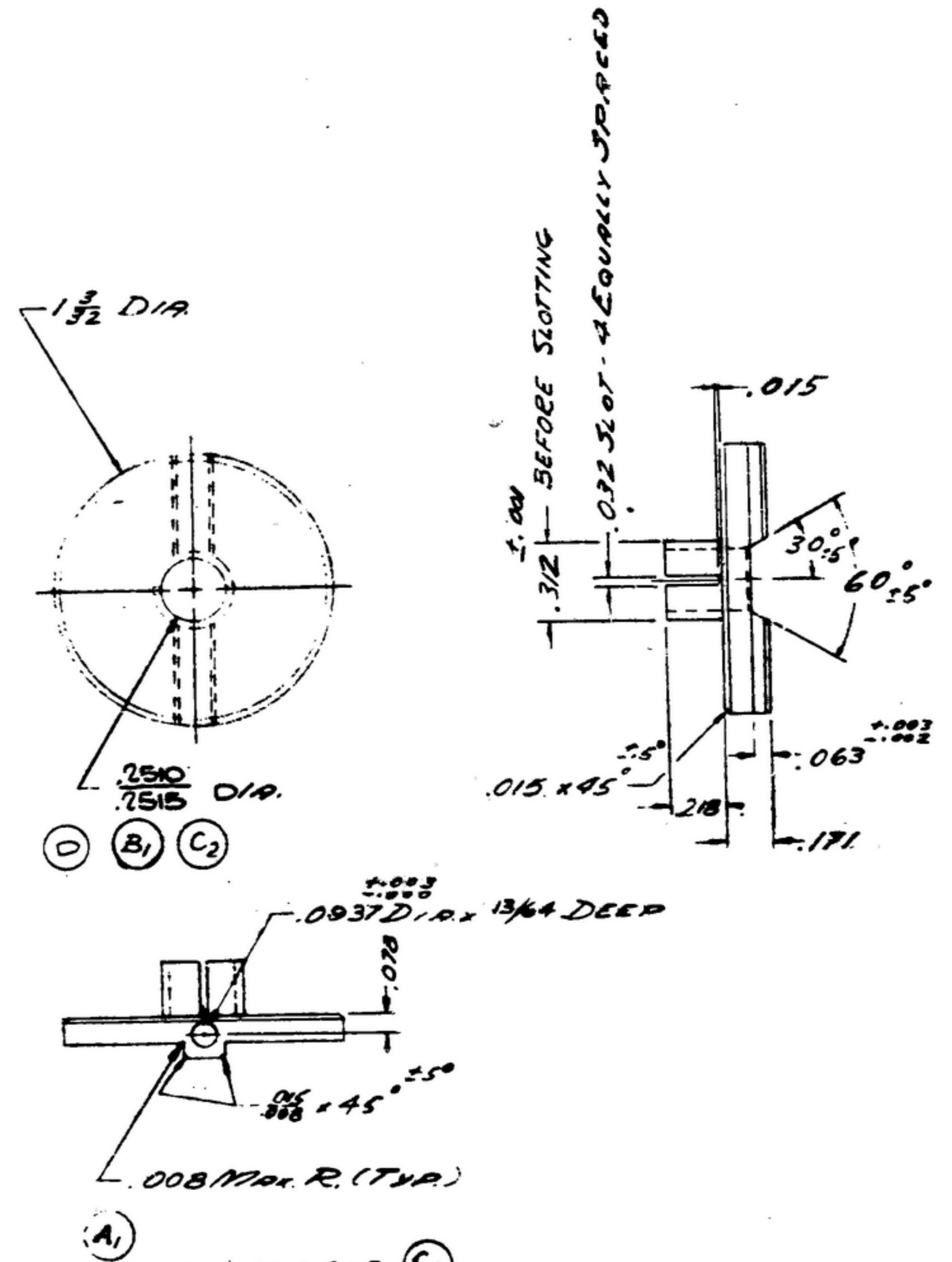

- ALUMINUM ALLOY CONDITION 4 PER SPEC QQ-A 26B. (C<sub>1</sub>)  
 FINISH E511 PER SPEC. MIL-F-14072. (A<sub>2</sub>)
- 1- REMOVE ALL BURRS & SHARP EDGES.
  - 2- SURFACE FINISHNESS NOT TO EXCEED 60 MICRO INCHES.
  - 3- POSITION OF SLOTS WITH REFERENCE TO BAR OR HOLE - UNIMPORTANT.

610 No. 1000310

LIST OF MATERIAL			
COUPLING			
UNLESS OTHERWISE SPECIFIED DIMENSIONS ARE IN INCHES TOLERANCES ON FRACTIONS DECIMALS ANGLES ± 1/64		AUTHENTICATION DRAWN 21832-PN- 50-93 TRACED PHOTO CHECKED [Signature] VERIFIED P.O.B.R. APPROVED P.O.B.R. REVIEWED P.M.E. DATE 28 JUL 53	SIGNAL CORPS ENGINEERING LABORATORIES FORT MONMOUTH NEW JERSEY <b>SM-C-178666</b>
SM-B-178665 SC-DL-248775	SM-B-178665 SC-DL-178467	SCALE 2/1	-90-543
NEXT ASSY	USED ON	APPLICATION	

WHEN REFERRING TO THIS DRAWING STATE DRAWING NO., APPLICABLE ISSUE SYMBOL, IF ANY, AND DATE