

R-391 506 1860

2.2

NOTICE: When Government drawings, specifications, or other data are used for any purpose other than in connection with a definitely related Government procurement operation, the United States Government hereby incurs no responsibility or any obligation whatsoever; and the fact that the Government may have furnished, furnished, or in any way supplied the said drawings, specifications, or other data is not to be regarded by implication or otherwise as in any manner licensing the holder or any other person or corporation, or conveying any rights or permission to manufacture, use or sell any patented invention that may in any way be related thereto.

NOTE:
*FOR INFORMATION ONLY,
CONTRACTOR MAY AT HIS
OPTION DEVIATE FROM
THESE PROCESS DETAILS

NEXT ASSEMBLY	USED ON	SWE	REVISIONS	DATE	APPROVAL
SM-C-178869	SC-DL-178467	APPROVAL	SYM		
SM-C-178869	SC-DL-248775	S	A ₃	6 OCT. 59	42428-PC-59 -A1-51. REV'D. PME
SM-C-343590		Y	B	15 OCT. 60	42428-PC-59 REV'D. PME
		M			
		CA			
		64853	B		(1)-ADDED NOTE #5.

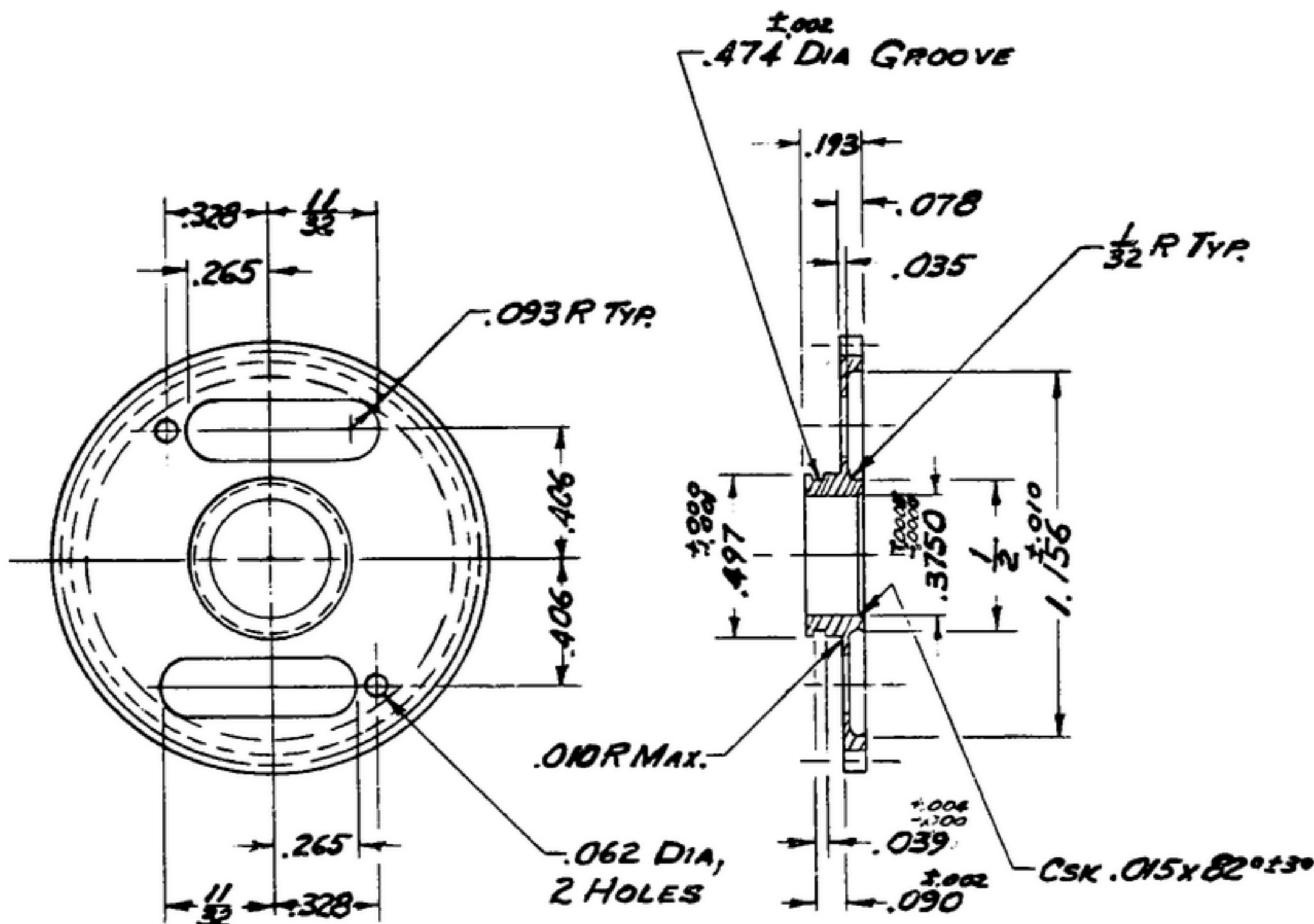

A₁

NOTES:

- 1.-BRASS COMP. 22, HARD, PER SPEC QQ-B-626. (A₃)
- 2.-NORMAL DIAMETRAL PITCH 48
THEORETICAL PITCH DIAMETER 1.3125
PRESSURE ANGLE 14½°
NUMBER OF TEETH 63
BACKLASH ON NORMAL PITCH CIRCLE WHEN MATED WITH MASTER .0015 - .0025
AMERICAN STANDARD TOOTH FORM
- 3.-ECCENTRICITY BETWEEN BORE DIAMETER & PITCH DIAMETER SHALL NOT EXCEED .002 TIR
- 4.-PART MUST BE FREE OF BURRS & SHARP EDGES.
- 5.-FINISH: CHEMICAL POLISH PER IRIDITE #7 METCOTE PROCESS BU, ALLIED RESEARCH PRODUCTS INC., BALTIMORE, MD., OR EQUAL.

B₁

UNLESS OTHERWISE SPECIFIED	AUTHENTICATION	DESCRIPTION	MATERIAL	SPEC	NOTE
DIMENSIONS ARE IN INCHES TOLERANCES ON FRACTIONS ± 1/64 DECIMALS ± .005 ANGLES ± COMMERCIAL TOLERANCES APPLY TO STOCK SIZES ALL SURFACES ✓	DRAWN 21857-TH 50-93 TRACED PHOTO CHECKED VERIFIED P.D.B.R. APPROVED P.D.B.R. REVIEWED PME DATE 30 JUN 59	GEAR			
					DEPARTMENT OF THE ARMY SIGNAL CORPS ENGINEERING LABORATORIES FORT MONMOUTH NEW JERSEY
					SM-C-178871

WHEN REFERRING TO THIS DRAWING STATE DRAWING NO., APPLICABLE ISSUE SYMBOL AND DATE