

2.5

R-391 506-1016-002

NOTICE: When Government drawings, specifications, or other data are used for any purpose other than in connection with a definitely related Government procurement operation, the United States Government thereby incurs no responsibility or obligation whatsoever and the fact that the Government may have formulated, furnished, or in any way supplied the said drawings, specifications, or other data is not to be regarded by implication or otherwise as in any manner constituting an endorsement, approval, or recommendation of the views or opinions of the contractor, or conveying any rights or privileges in manufacture, use or sale of any patented invention that may in any way be related thereto.

NOTE: FOR INFORMATION ONLY, CONTRACTOR MAY AT HIS OPTION DEVIATE FROM THESE PROCESS DETAILS

REV. NO.	DATE	DESCRIPTION	APPROVAL
A <sub>3</sub>	8 OCT. 59	A <sub>1</sub> - RENUMBERED NOTES; A <sub>2</sub> - ADDED APPL. SM-B-178935, SC-DL-248775 A <sub>3</sub> - BRASS WAS PER SPEC. QQ-B-611.	REV'D. P.M.E.
B <sub>1</sub>	23 FEB. 60	B <sub>1</sub> - BRASS WAS PER SPEC. QQ-B-626.	REV'D. P.M.E.
C <sub>1</sub>	15 SEPT. 60	C <sub>1</sub> - ADDED NOTE 5	REV'D. P.M.E.

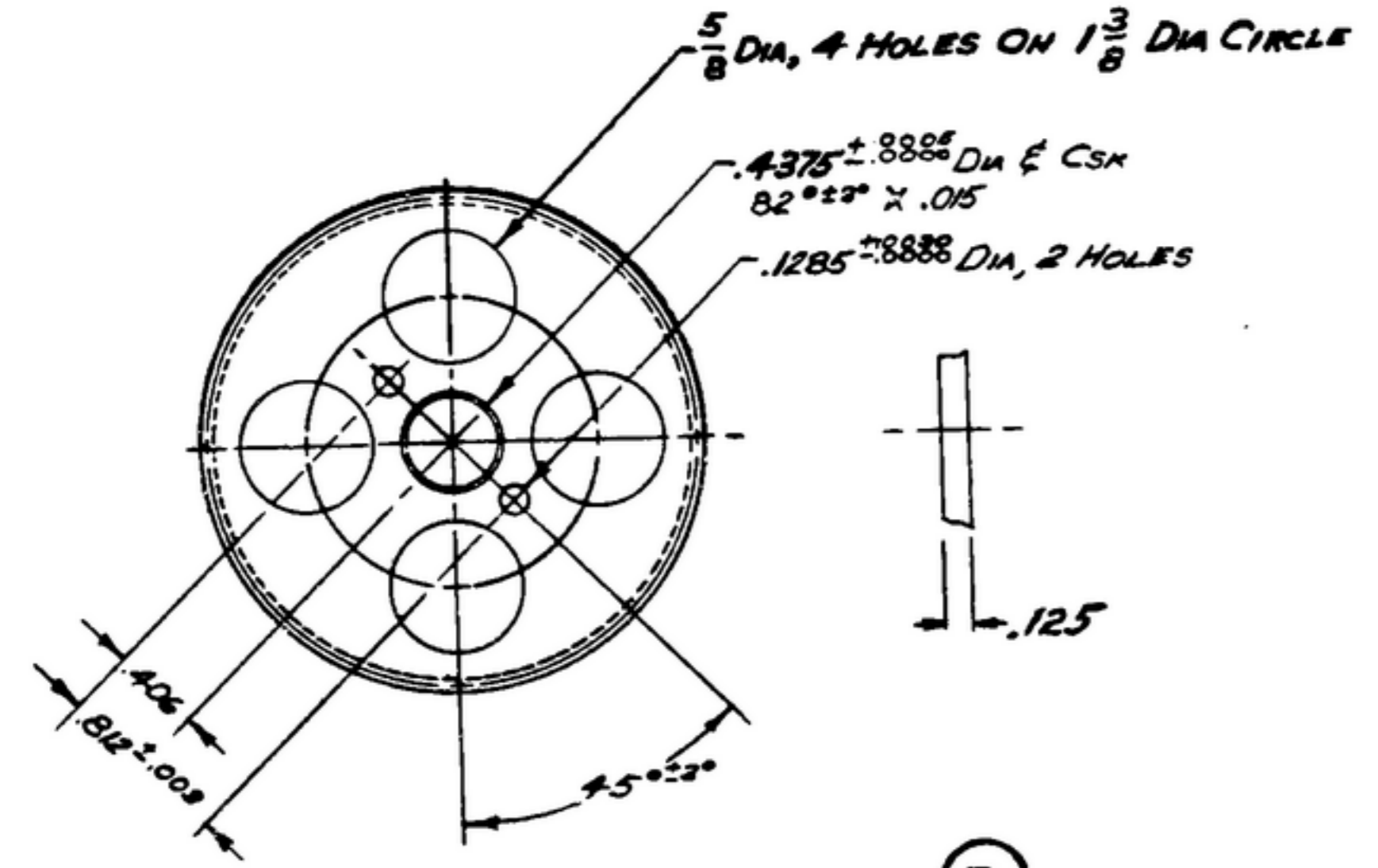

- NOTES:
- 1.-BRASS, COMP 1, 1/2 H PER SPEC QQ-B-613.
  - 2.-GEAR DATA  
 NORMAL DIAMETRAL PITCH 32  
 NORMAL PRESSURE ANGLE 20°  
 NUMBER OF TEETH 75  
 THEORETICAL PITCH DIAMETER 2.3437  
 BACKLASH .002 TO .003 WHEN REFERRED TO THE THEORETICAL PITCH CIRCLE  
 AMERICAN STANDARD INVOLUTE TOOTH FORM  
 ALL TERMS USED AS DEFINED BY AGMA STANDARDS
  - 3.-ECCENTRICITY BETWEEN PITCH DIAMETER AND BORE MUST NOT EXCEED .002 TIR
  - 4.-REMOVE ALL BURRS AND SHARP EDGES.
  - 5.-FINISH: CHEMICAL POLISH PER IRIDITE #7 METCOTE PROCESS BY ALLED RESEARCH PRODUCTS INC. BALTIMORE, MD. OR EQUAL.

UNLESS OTHERWISE SPECIFIED	AUTHENTICATION	<b>GEAR</b>	DEPARTMENT OF THE ARMY SIGNAL CORPS ENGINEERING LABORATORIES FORT MONMOUTH NEW JERSEY
DIMENSIONS ARE IN INCHES	DRAWN L1052-PH-50-99		
TOLERANCES ON FRACTIONS ± 1/64	TRACED PHOTO		
DECIMALS ± .005	CHECKED <i>[Signature]</i>		
ANGLES ±	VERIFIED P.D.B.R.		
COMMERCIAL TOLERANCES APPLY TO STOCK SIZES	APPROVED P.D.B.R.	SCALE 2/1	SM-C-178936
ALL SURFACES	REVIEWED P.M.E.	DATE 19 JUN 53	

WHEN REFERRING TO THIS DRAWING STATE DRAWING NO., APPLICABLE ISSUE SYMBOL AND DATE