

APPROVED: THESE GOVERNMENT DRAWINGS, SPECIFICATIONS, OR OTHER DATA ARE USED FOR ANY PURPOSE OTHER THAN IN CONNECTION WITH A GOVERNMENTALLY RELATED PROCUREMENT OPERATION. THE UNITED STATES GOVERNMENT TAKES NO RESPONSIBILITY FOR ANY CONSEQUENT INACCURACIES. AND THE FACT THAT THE GOVERNMENT HAS MADE, FORMULATED, PROVIDED, OR IN ANY WAY SUPPLIED THE SAME DRAWINGS, SPECIFICATIONS, OR OTHER DATA IS NOT TO BE CONSIDERED AN ENDORSEMENT OR APPROVAL OF THE PRODUCTS OR THE MANUFACTURE THEREOF, NOR SHALL ANY PATENTED INVENTIONS THAT MAY IN ANY WAY BE RELATED THEREOF.

"THIS DOCUMENT HAS BEEN PURCHASED BY THE GOVERNMENT AND MAY BE REPRODUCED AND USED IN CONNECTION WITH ANY GOVERNMENT PROCUREMENT OR MAINTENANCE OPERATION."

NOTE:  
\*FOR INFORMATION ONLY, CONTRACTOR MAY AT HIS OPTION DEVIATE FROM THESE PROCESS DETAILS

REVISIONS			
SYM	DESCRIPTION	DATE	APPROVAL

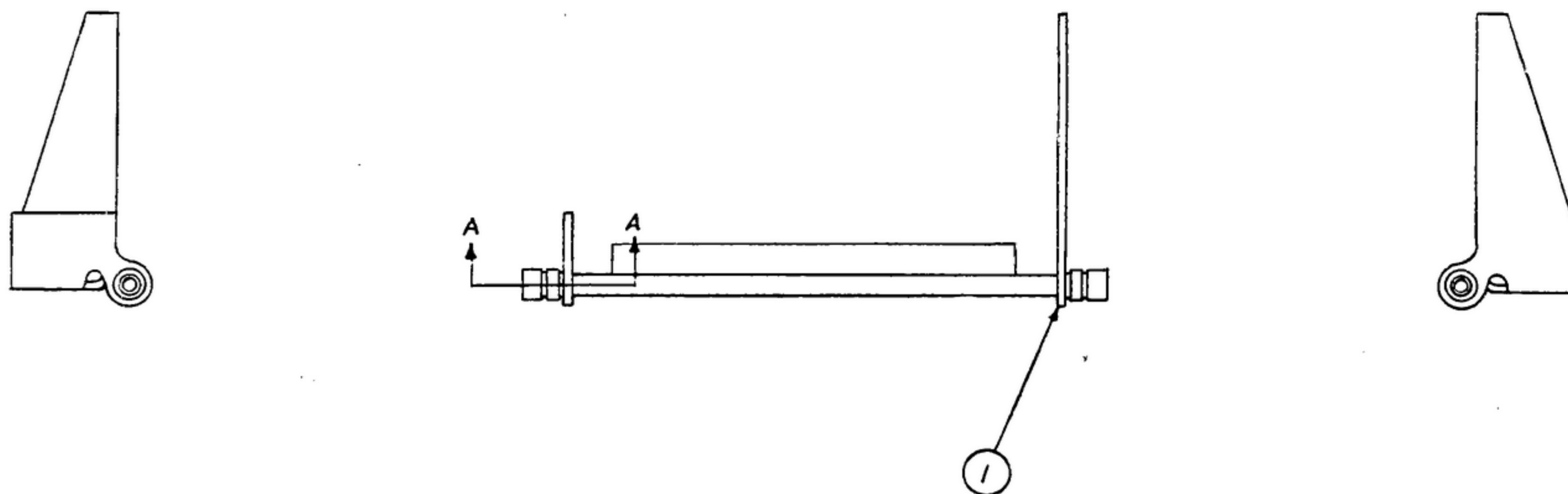

NOTES:  
1. ROLLERS MUST ROTATE FREELY AFTER STAKING  
2. ROLLER BORE TO BE LUBRICATED WITH OIL (T) PER SPEC MIL-L-7870 BEFORE ASSY  
3. IN ALL SPLIT BOLLOONS TOP FIGURE IS MATERIAL LIST ITEM INDICATOR & BOTTOM FIGURE IS QUANTITY.

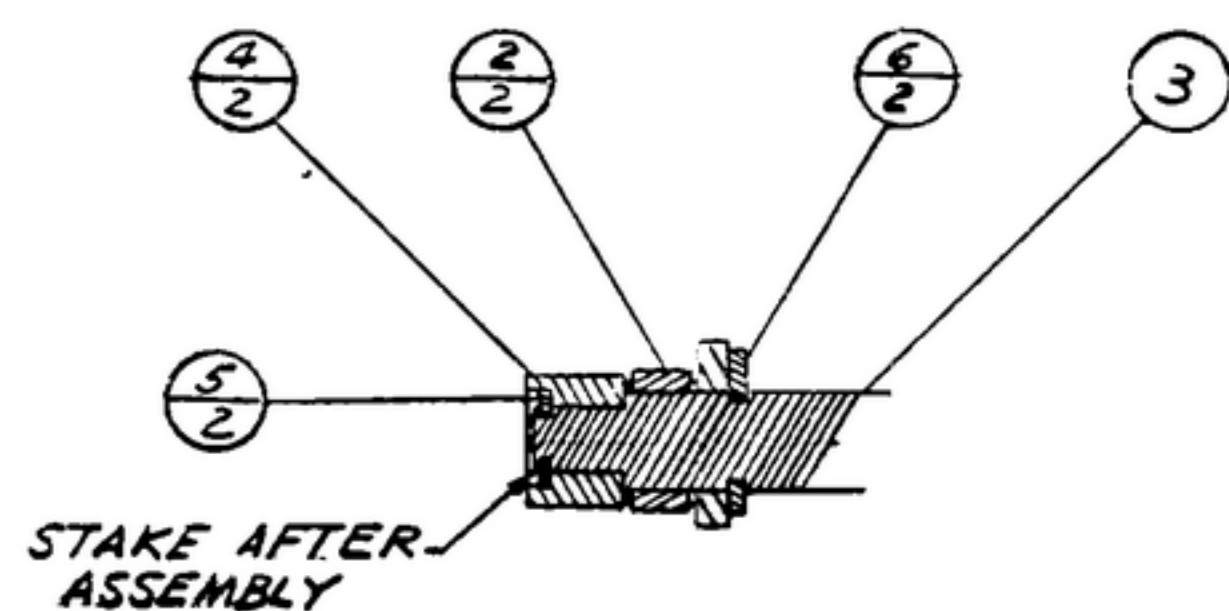

SECTION A-A  
TYPICAL BOTH ENDS OF SHAFT  
SCALE: 2/1

ITEM	SWE PART NO	REQD	PART NO.	DESCRIPTION	MATL	MATL SPEC	NOTE
7	15111255-6	AS REQD	—	LUBRICANT			2
6		2	MS-16633-9017	RING RETAINING			
5		2	SM-B-170822	WASHER			
4	574210	2	SM-B-178739	ROLLER			
3		1	SM-B-343611-1	SHAFT			
2		2	SM-B-343610-1	BEARING			
1		1	SM-C-249075	RACK-HIGH			

## LIST OF MATERIAL

UNLESS OTHERWISE SPECIFIED		STEWART-WARNER ELECTRONICS- ORDER NO.		RACK ASSY-I.F.		DEPARTMENT OF THE ARMY SIGNAL CORPS ENGINEERING LABORATORIES	
DIMENSIONS ARE IN INCHES		42428-PC-59					
TOLERANCES ON		SIGNAL CORPS		REVIEWED PME		FORT MONMOUTH NEW JERSEY	
FRACTIONS DECIMALS ANGLES		APPROVED					
Drawn By: P. J.		PME		SCALE 1/1		SM-C-343632	
Checked By: J. J. DeBonghi		PME					
Chief Drafts: C. J. Dalloway		DATE 27 OCT 59					
Eng Approval: [Signature]							
SM-D-343629 SG-DL-248775		APPLICATION					
NEXT ASSY USED ON							