

proposal for

Incorporation of 100 cps Tuning Increments in the AN/WRC-1 Radio Set

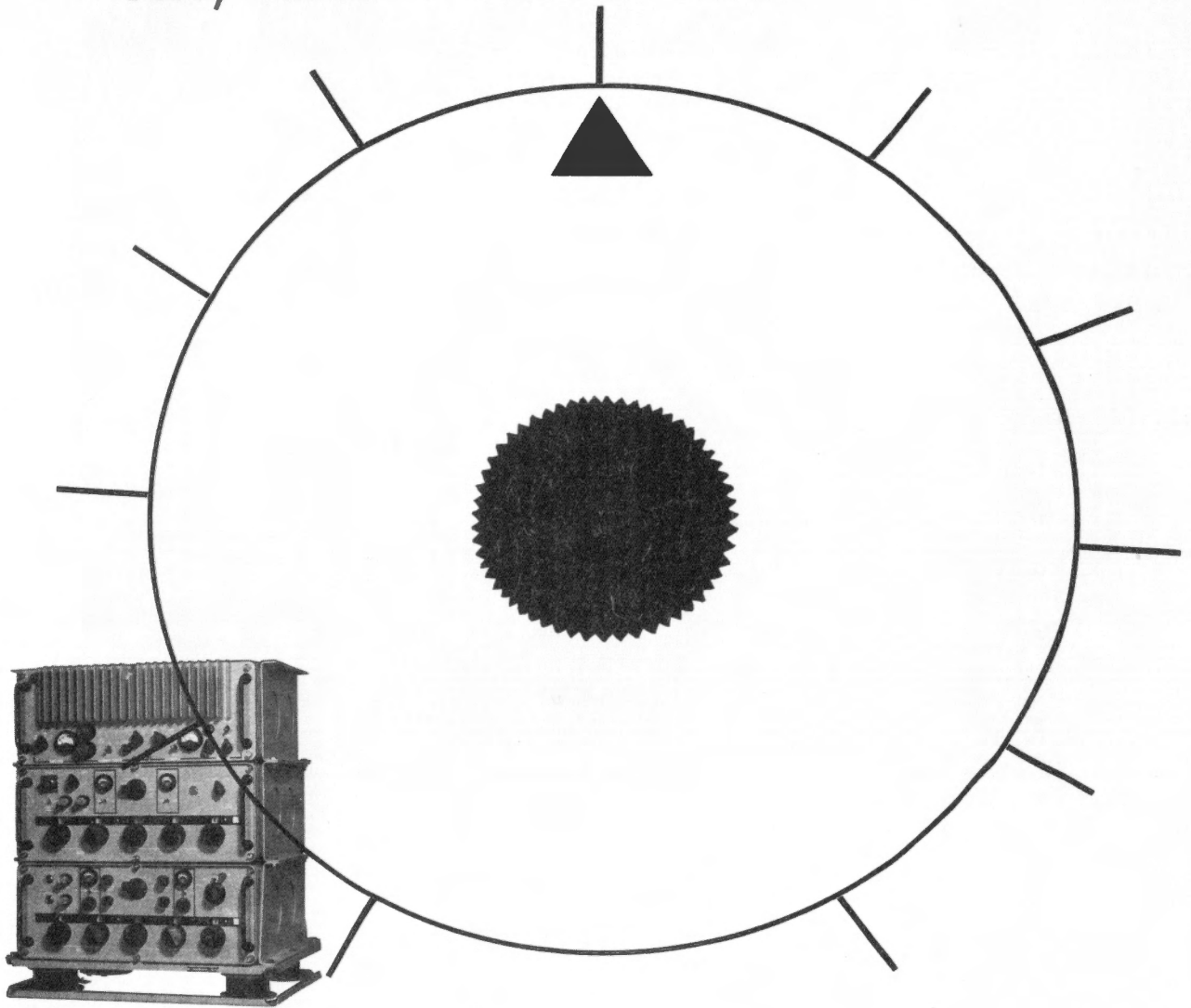

GD

GENERAL DYNAMICS | ELECTRONICS

proposal for

Incorporation of 100 cps Tuning Increments in the AN/WRC-1 Radio Set

PIN 3-0564-51

8 NOVEMBER 1963

DATA CLAUSE

"The data furnished in this proposal shall not be disclosed outside the Government or be duplicated, used or disclosed in whole or in part for any purpose other than to evaluate the proposal; provided, that as a contract is awarded to this offeror as a result of or in connection with the submission of such data, the Government shall have the right to duplicate, use, or disclose this data to the extent provided in the contract. This restriction does not limit the Government's right to use information contained in such data if it is obtained from another source."

GD

GENERAL DYNAMICS | ELECTRONICS

1400 North Goodman Street, P. O. Box 226, Rochester 1, New York

1. INTRODUCTION

It is the understanding of General Dynamics/Electronics that there exists within Naval Communications the requirement for tuning of high frequency receivers and transmitters in increments of 100 cps.

The tuning of a 2 to 30 mc receiver or transmitter in highly stable 100 cps increments is not one of the easiest tasks to perform. To further impose the limitations of utilizing minimum space to accomplish the 100 cycle tuning, ease of tuning, and no degradation of the basic frequency stability of the receiver or transmitter further complicates the task. However, as is well known to the cognizant BuShips engineer, General Dynamics/Electronics, over the past few years, has been constantly striving for improvements in the area of frequency translation and synthesis. Indeed, it was study and design effort under Company sponsorship that permitted General Dynamics/Electronics to undertake with high assurance of success, the incorporation of 500 cps steps in the R-1051/URR Receiver and the T-827/URT Transmitter for the AN/WRC-1 Radio Set.

Further study and development work in the area of high-stability frequency synthesizers now permits GD/E to propose to BuShips a modification to the WRC-1 equipments for 100 cps tuning with the same high assurance of success of the previous 500 cps tuning. As was stated previously, it is our understanding that the need for 100 cps tuning exists today. General Dynamics/Electronics currently has the techniques to implement the 100 cycle tuning in the AN/WRC-1 Radio Set and is vitally interested in placing this experience and competence in the area of high stability translators and synthesizers at the disposal of the Bureau of Ships.

To this end, we respectfully submit this unsolicited technical proposal which we feel is the optimum solution to the addition of 100 cycle tuning increments to the AN/WRC-1 Radio Set.

2. DISCUSSION OF THE PROBLEM

The R-1051/URR Receiver and the T-827/URT Transmitter are currently capable of being tuned in locked increments of 500 cps. The major tasks that would confront the design engineer in the program of incorporation of 100 cycle locked tuning in these units would be that of including the necessary circuitry with a minimum of change to existing proven circuitry, ease of incorporating controls, and a design that would lend itself for easy retrofit in current models of the AN/WRC-1 Radio Set.

The technical discussion in Section 3 covers the operation of the present circuitry of the translator-synthesizer and the necessary modifications and additions required to permit 100 cycle increment tuning of the R-1051/URR Receiver and T-827/URT Transmitter. It should also be noted that the proposed 100 cycle incremental tuning modification is directly applicable to the AN/URC-35 Radio Set as well as the AN/WRC-1 due to the commonalty of the translator-synthesizer electronic subassembly.

3. TECHNICAL DISCUSSION

3.1 General

The Translator/Synthesizer represents the triple conversion section of the present AN/WRC-1 System and is used in the equipment in two discrete modes. In the R-1051 Receiver, the Translator/Synthesizer converts the desired RF input signal to the final IF frequency in locked 500 cps increments. A vernier control is provided for reception between discrete frequency increments. In the T-827 Transmitter, the Translator/Synthesizer converts the input IF signal to the desired RF output frequency in locked 500 cps steps, thus providing 56,000 discrete frequencies in the 2 to 30 mc range. In both cases, the translation process is accomplished without the generation of detrimental spurious responses or intermodulation products.

In both the RECEIVE and TRANSMIT mode, the injection to the various mixers is achieved by means of frequency synthesized outputs that have the same frequency stability as that of the frequency standard. The frequencies generated in the synthesizer are directly controlled by the digital frequency knobs on the front panel, which operate a combination of mechanical drives and electrical control functions. A general block diagram of the Translator/Synthesizer is shown in Figure 1, with a more detailed diagram in Figure 2.

In the RECEIVE mode, a signal in the range of 2 to 30 mc is obtained from the RF amplifier by the HF mixer (R). The injection for this mixer is from the mc synthesizer and in accordance with the scheme. The RF signal is translated to IF frequencies of either 20 mc or 30 mc. Seventeen injection frequencies are used to cover the 28 1-megacycle increments between 2 mc and 30 mc. The two IF frequencies are obtained by switching the output of the HF mixer (R) to either a 20 mc or 30 mc bandpass filter. The output of these filters provides an IF input to the MF mixer (R), whose oscillator injection is obtained from the 100 kc synthesizer. The output from the mixer drives a bandpass filter (100 kc wide)

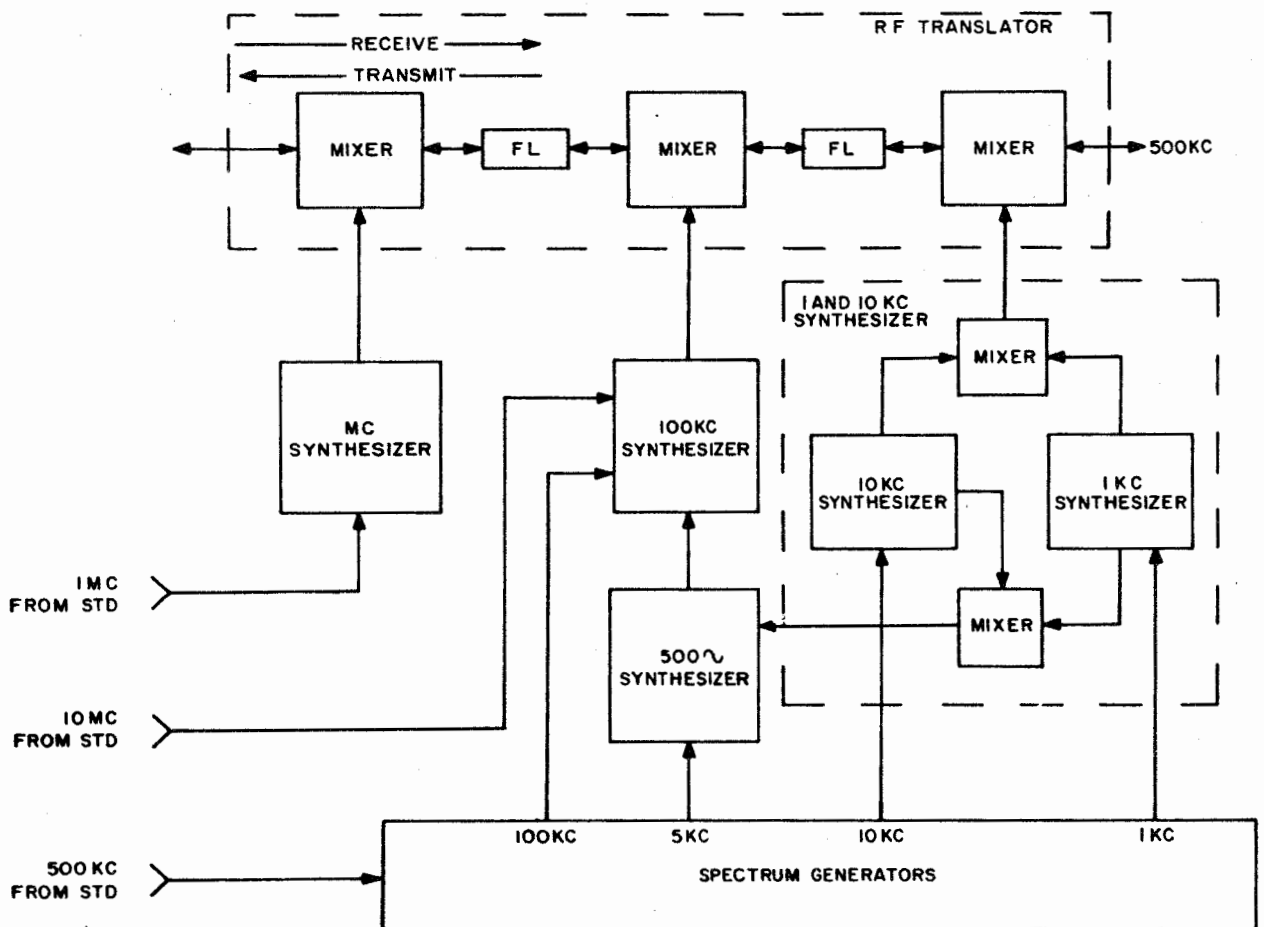

Figure 1. Translator/Synthesizer, Basic Block Diagram.

centered at 2.85 mc. The output of this filter is used as an input to the LF mixer (R) and when combined with the injection from the 1 and 10 kc synthesizer, the output of this stage results in the final IF frequency of 500 kc.

In the TRANSMIT mode, the injection from the 1 and 10 kc synthesizer is mixed in the LF mixer (T) with the 500 kc from the Transmitter IF module. The output of this mixer is coupled into the 2.85 mc IF filter, whose output then drives the MF mixer (T). The injection for the MF mixer (T) is from the 100 kc synthesizer. The output of this mixer is coupled to either the 20 mc or 30 mc filter in accordance with the requirements of the frequency scheme. The output of these filters are

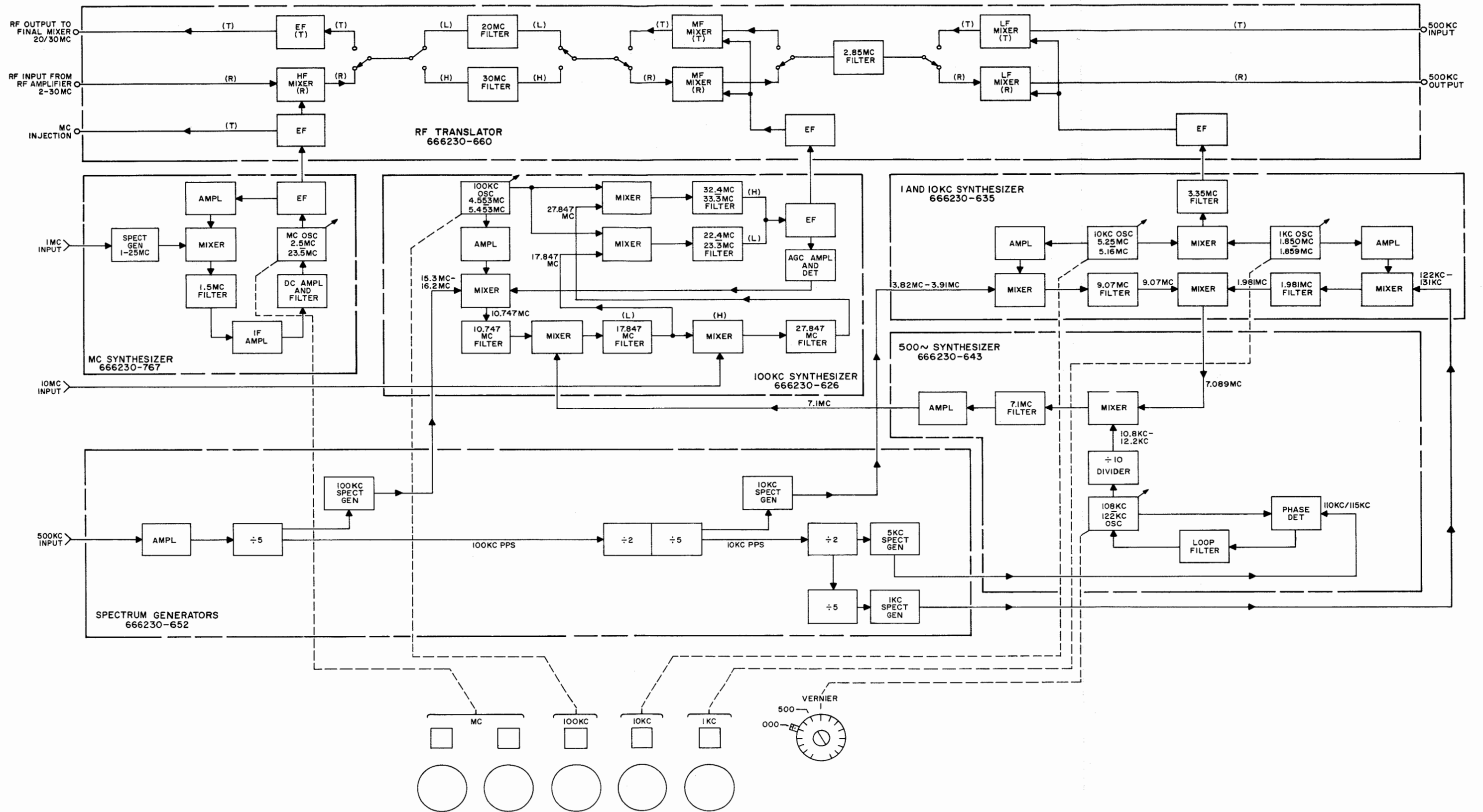

Figure 2. Translator/Synthesizer, Detail Block Diagram.

used to drive the HF mixer in the RF amplifier module. The oscillator injection for this mixer is obtained from the mc synthesizer.

All switching functions in the RF translator are performed by diode gate circuitry. Diode gates are used to select the 20 mc or 30 mc IF bandpass filter. Along with this, these gates control the signal path to all the filters and mixer stages in accordance with the mode of operation (TRANSMIT or RECEIVE).

In the synthesizers, a combination of error cancelling loops and phase locked loops are used to provide the proper injections for the various mixers in the RF translator. The 1 and 10 kc synthesizer employs an error cancelling scheme whose error cancelling loop includes the 500 cps synthesizer, 100 kc synthesizer and the signal path between the MF mixer and the LF mixer. The 100 kc synthesizer also employs an error cancelling scheme, but its loop is contained within the unit and does not involve any other modules. The mc synthesizer and the 500 cps synthesizer both employ phase locked loops and are self contained. The spectrum generator module provides a variety of frequencies that are locked to the standard, and consequently provides the necessary reference frequency required by the synthesizers. Figure 3 shows the layout of the present module.

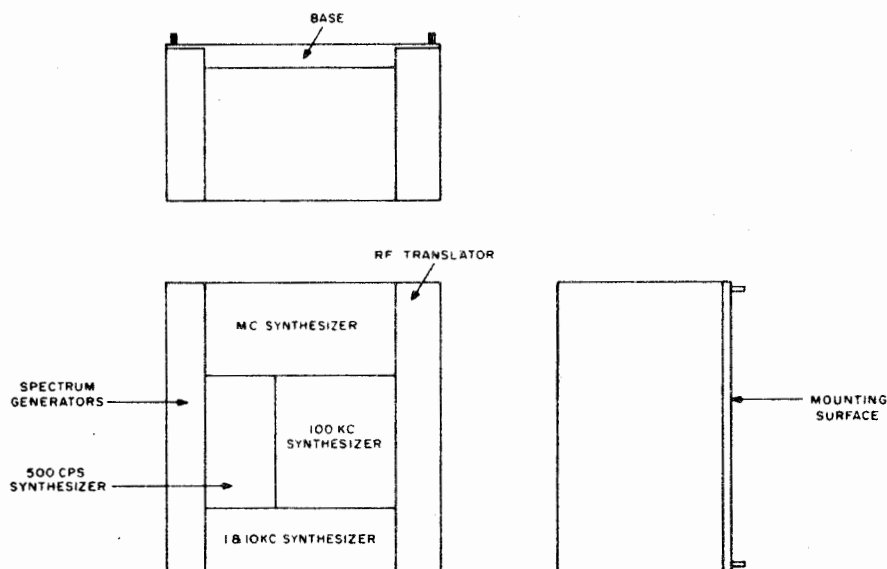

Figure 3. Translator/Synthesizer Packaging.

3.2 Method of Implementing 100 cps Tuning Increments

The 500 cps synthesizer used in the R-1051 Receiver and the T-827 Transmitter is identical in circuit design and configuration. The only difference between the Receiver and Transmitter is that the Receiver has a VERNIER mode of operation besides the "000" and "500" cps locked positions. In the locked positions, a fixed voltage is applied to the voltage variable capacitors (VVC) in the oscillator circuit, while in VERNIER operation a variable voltage is used to tune the oscillator over the frequency range. The input to the 500 cps synthesizer is from the 1 and 10 kc synthesizer. This signal path is part of the error cancelling loop for the 1 and 10 kc synthesizer, and consequently contains the error of the crystal oscillators in this unit. In the 500 cps synthesizer, this signal is mixed with the injection from the 500 cps oscillator, providing an output to the 100 kc synthesizer. Since the 100 kc synthesizer is in the error loop of the 1 and 10 kc synthesizer, the output of the 500 cps synthesizer also contains the error from the 1 and 10 kc synthesizer.

The 500 cps synthesizer is a phase locked system and consists of three sub-assemblies. As shown in Figure 4, the oscillator is phase locked to the output of the spectrum generator and provides an output to the divider. In the "000" and "500" cps positions, the oscillator is locked at 110 kc and 115 kc, respectively, while in the VERNIER position, it is tuned over a range 108 kc to 122 kc. Tuning in all positions is accomplished by means of voltage variable capacitors that form an integral part of the oscillator's feedback network. A 5 kc spectrum is employed to provide the 110 kc and 115 kc spectrum frequencies that are used as references in the phase locked loop. As can be seen, the output of the oscillator is locked in a 5 kc increment. However, as a system requirement, it is necessary to lock in 500 cycle increments. Consequently, the output of the oscillator is divided down by a factor of ten in the divider subassembly. The output of the divider then covers a range of 10.8 kc to 12.2 kc in VERNIER operation, and 11.0 kc or 11.5 kc in the locked positions. This output is then coupled into a tuned amplifier on the 7.1 mc mixer subassembly that has a center frequency of about 11.5 kc and is used to pass only the fundamental frequency of the divider output to the 7.1 mc mixer stage. The signal from this amplifier is mixed with

the input from the 1 and 10 kc synthesizer and the output of the mixer is coupled into a crystal filter. The bandpass of this filter is sufficiently wide to accommodate the 1,400 cps range requirement in VERNIER operation and the oscillator error from the 1 and 10 kc synthesizer. Neglecting the error from the 1 and 10 kc synthesizer, the output of the 7.1 mc mixer is 7.100000 mc in the "000" cps position and 7.100500 mc in the "500" cps position. Since loop cancellation of the 1 and 10 kc oscillator error is accomplished via this signal path to the 100 kc synthesizer, any displacement of this error signal results in the same frequency change in the 100 kc injection. This frequency displacement is not

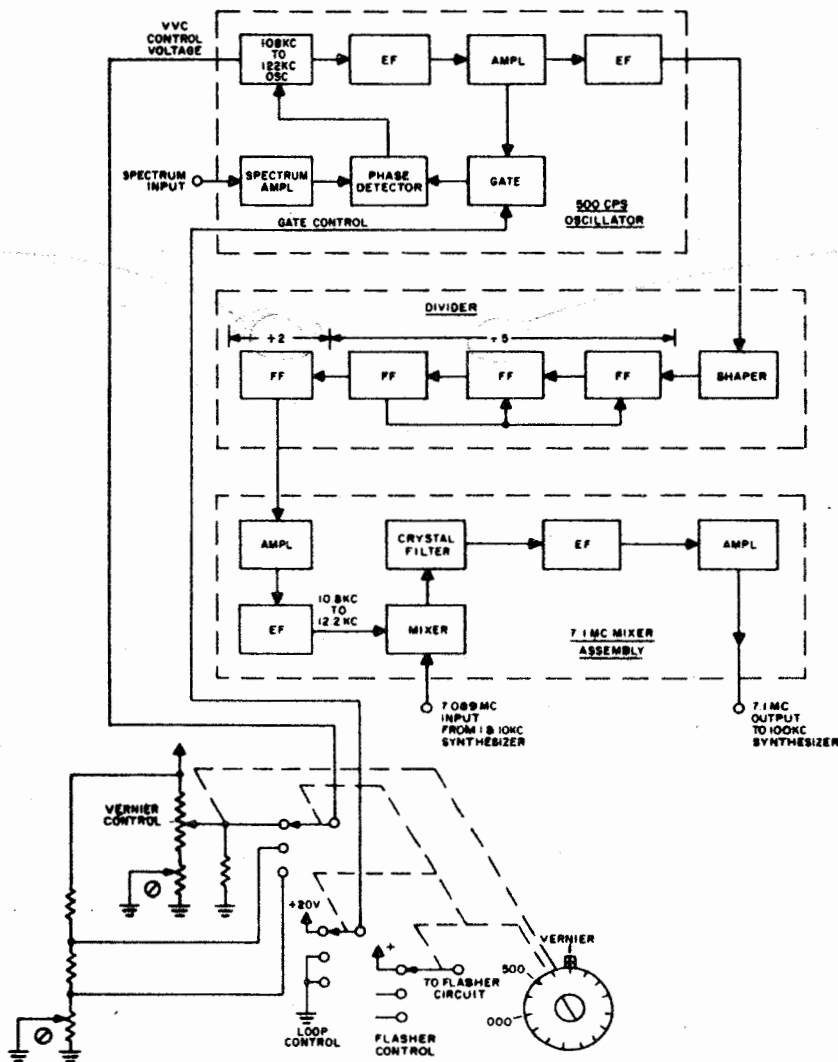

Figure 4. 500 cps Synthesizer.

cancelled in the translator as is the error of the 1 and 10 kc synthesizer. Consequently, a 500 cps displacement in the nominal 7.1 mc results in a 500 cps shift in the 100 kc injection, thus permitting conversion of signals in 500 cycle increments with the stability of the frequency standard.

This method of tuning offers a flexible means of providing a variety of tuning functions without incurring a major redesign of the Translator/Synthesizer. Consequently, in order to provide 100 cps incremental tuning, it will only be necessary to replace the 500 cps synthesizer with a 100 cps synthesizer and slightly modify the spectrum generator to accommodate the spectrum requirements of the new module. The layout of the present 500 cps synthesizer module is shown in Figure 5.

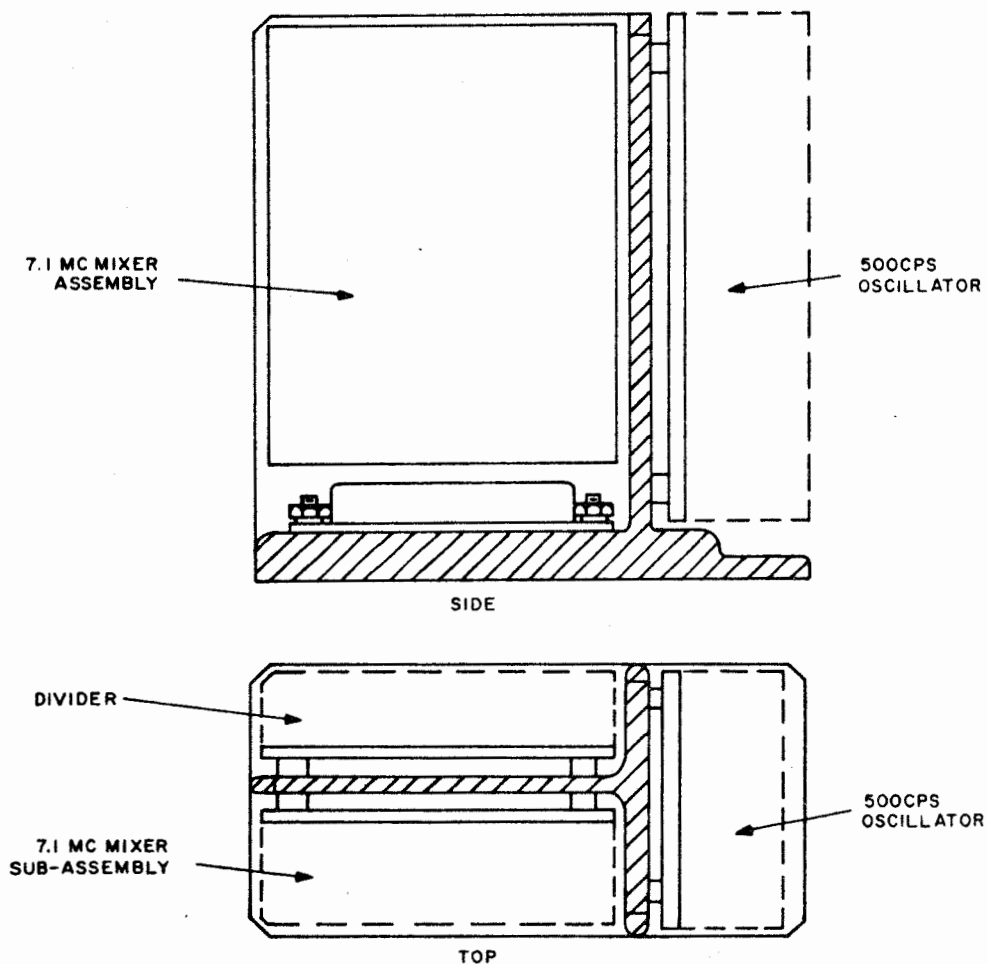

Figure 5. 500 cps Synthesizer Module Layout.

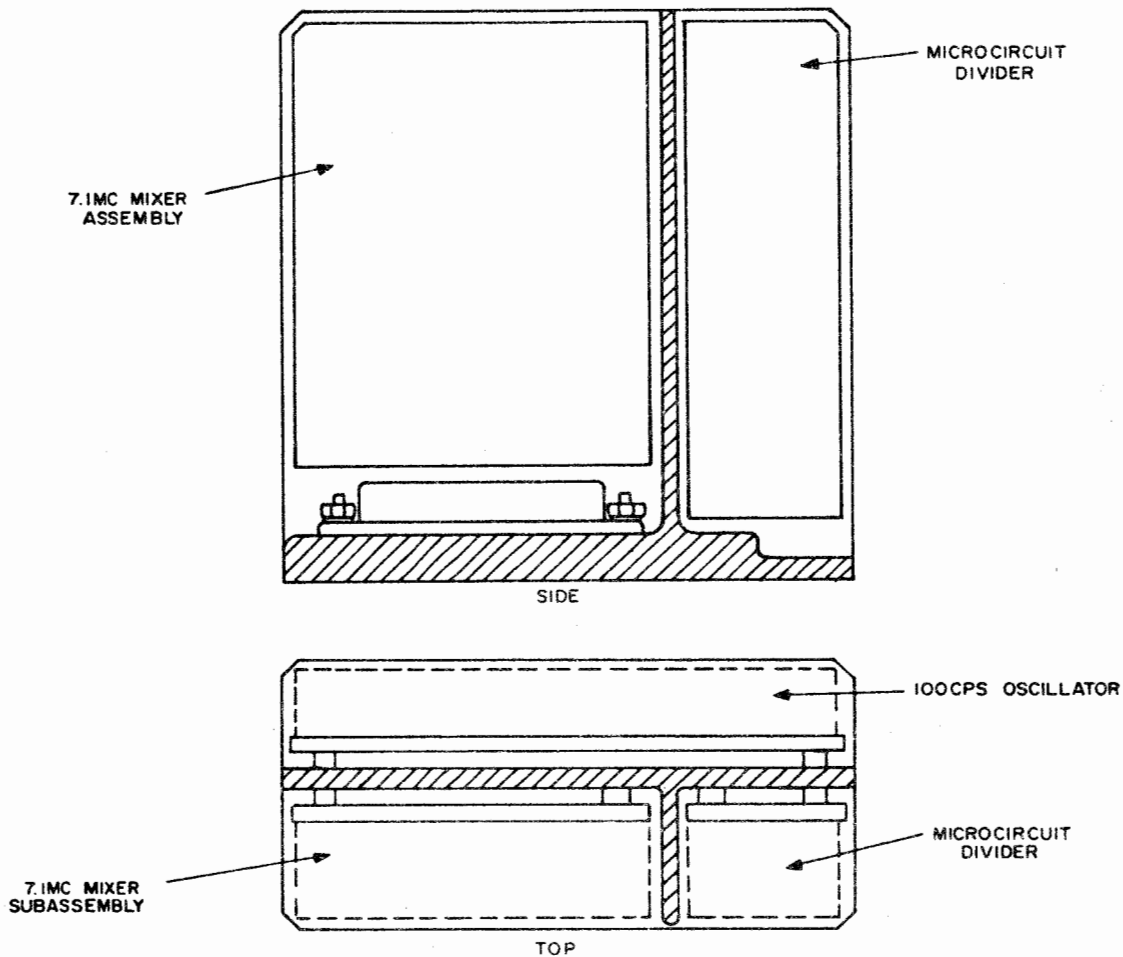

Figure 6. Proposed 100 cps Synthesizer Module Layout.

The proposed 100 cps synthesizer is shown in Figure 6. In the 100 cps module, the 7.1 mc mixer subassembly remains unchanged, while both the oscillator and divider subassemblies have been redesigned. The oscillator to be used will remain basically unchanged, but due to the additional requirements of 100 cps increments, modifications in the phase lock loop are necessary. Since additional volume will be required for the oscillator subassembly, the divider circuitry will be reduced in size to make room for the increased space required by the oscillator subassembly. The divider circuitry used in the 500 cps synthesizer employs conventional circuit components. By means of microcircuit techniques this can be reduced considerably in size. The divider subassembly to be used in the 100 cps

synthesizer will employ the same circuit configuration as the 500 cps synthesizer unit, but the bistable multivibrators will be separate and interchangeable micro-circuits. This will permit a size reduction of the divider subassembly into the space shown in Figure 6.

The other changes to the R-1051 Receiver and T-827 Transmitter will involve the modification of the spectrum generator to provide a 1 kc reference spectrum for the phase locked loop and the replacement of the front panel control with an eleven position switch. This switch will select either vernier operation or locked 100 cps increments from "000" to "900" cps.

3.3 Proposed Approach

In the proposed 100 cps synthesizer, the basic approach taken for the 500 cps synthesizer will be retained and a phase locked oscillator will be employed to provide the 100 cps tuning increments. This oscillator, in an unlocked mode and voltage variable capacitor tuned, will also be capable of providing a VERNIER mode of operation. In the system, the VERNIER will cover a tuning range of slightly greater than 1,000 cps. As in the present 500 cps synthesizer, the output of the oscillator provides a sinusoidal output to the divider subassembly, which divides this frequency by a factor of ten and serves as the injection to the mixer on the 7.1 mc mixer subassembly. The injection from the divider is then mixed in this stage with an input from the 1 and 10 kc synthesizer. The output of this mixer is used to drive the 100 kc synthesizer. A block diagram of the proposed 100 cps synthesizer is shown in Figure 7.

From the discussion given, it can be seen that the proposed 100 cps synthesizer has retained the basic concept of the 500 cps synthesizer and that only the oscillator requirements have been changed. For reasons outlined in the later discussion of the oscillator design requirements, it will be necessary to increase the size of the oscillator subassembly. To provide for this and still remain within the confines of the existing module, it will be necessary to reduce the size of the divider subassembly. Since the function of the 7.1 mc mixer subassembly

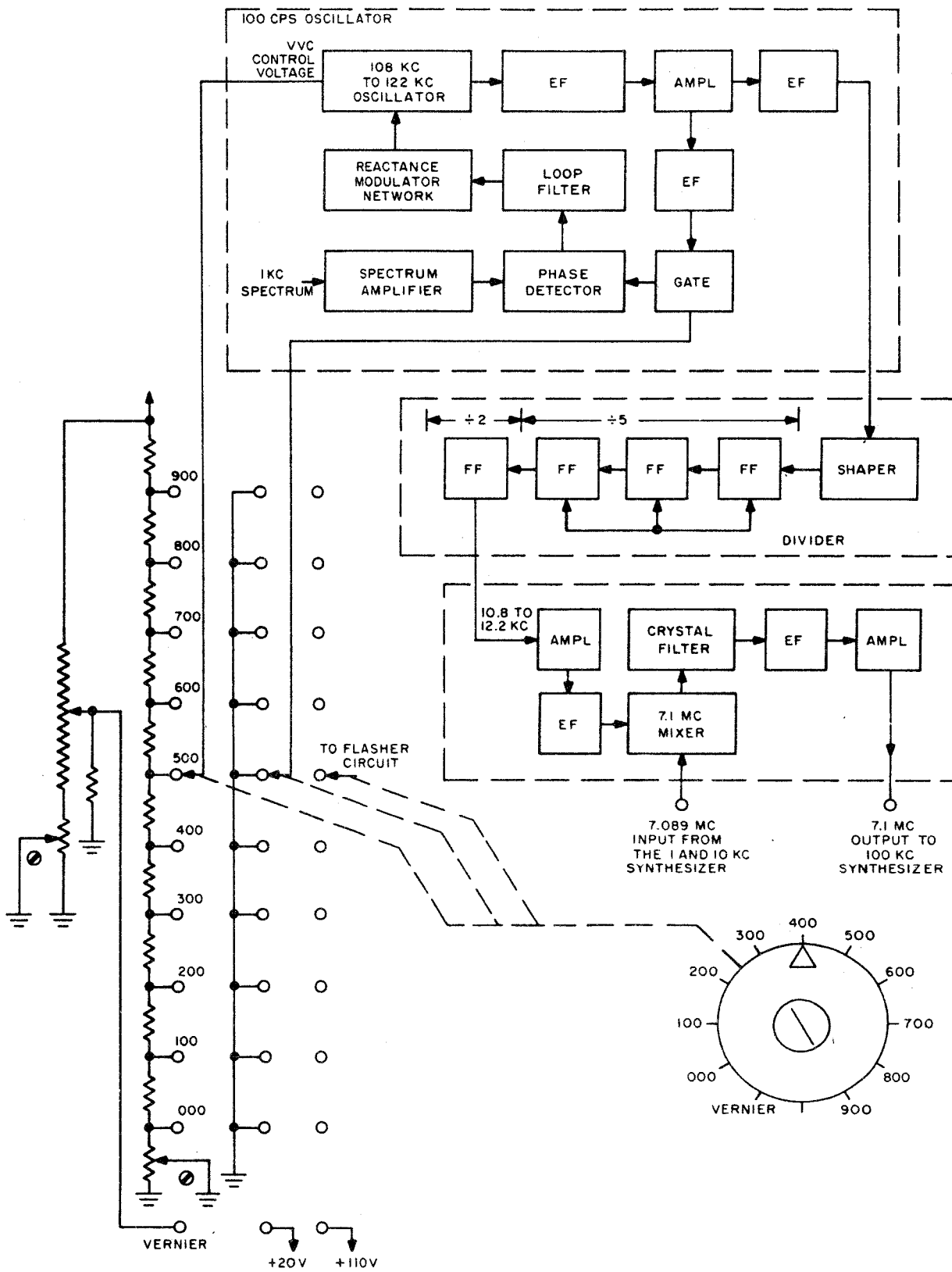

Figure 7. Proposed 100 cps Synthesizer.

has not changed from the existing unit, and combined with the fact that very little space can be saved due to the presence of the crystal filter on this board, the divider appears to be the most logical choice. The divider's electrical requirements remain the same as they were in the 500 cps synthesizer and consequently, could be used in the 100 cps synthesizer. However, since this unit is constructed of standard components, the use of microcircuit techniques to accomplish the same functional requirements will provide the necessary reduction to accommodate the increase in size of the oscillator subassembly. The proposed layout of the 100 cps synthesizer has been given in Figure 6 of the previous section.

Since the divider circuits consist of four bistable multivibrators connected so as to form a divide by ten circuit, it is possible to employ microcircuit or integrated circuit techniques to realize a space savings for this subassembly. Bistable multivibrators developed by integrated circuit techniques employ standard transistor packaging to provide a self-contained circuit, while microcircuit techniques utilize thin film resistor and capacitor circuitry along with conventional semiconductors to provide a compact unit. Although the microcircuits are larger than the integrated circuits, the space that has been allotted in the 100 cps synthesizer is sufficient to utilize either approach. Consequently, the reduction in size of the divider subassembly is entirely feasible and does not present any unusual problem.

In the 500 cps synthesizer, the phase locked oscillator is locked at 110 kc and 115 kc. The reference frequency used to lock the oscillator at these frequencies is obtained from the 5 kc spectrum generator. This unit consists basically of a gated oscillator whose output is a sinusoidal burst of about 100μ sec duration at a 5 kc rate. When an oscillator is keyed at a given rate, there is a frequency spectrum generated, whose spectral distribution is centered about the oscillator's free-running frequency and whose spectral points are separated by the keying rate. The energy distribution of the spectrum is determined by the keying or gate duration. Consequently, for the 5 kc spectrum, the oscillator's frequency is adjusted such that the 110 kc and 115 kc spectral frequencies are equal. Since the gate

duration is 100μ sec, these spectrum points are the predominant amplitudes that lie within the main lobe of the spectral distribution. In order to achieve 100 cps incremental tuning, it will then be necessary to employ a 1 kc spectrum. Consequently, the gated oscillator and the associated circuitry in the spectrum generator module will have to be modified to meet this spectrum requirement.

In the 500 cps synthesizer, the maximum cutoff frequency for the phase locked loop was about 700 cps. Since a 5 kc spectrum was used for this module, the ripple out of the phase detector consists mainly of this 5 kc keying rate. In order to minimize this ripple and to prevent detrimental frequency modulation of the oscillator, a filter was used on the output of the phase detector. Since the basic ripple rate is 5 kc, the phase shift due to this filter was well beyond the cutoff frequency of the loop. However, the use of a 1 kc spectrum for the 100 cps synthesizer results in a 1 kc ripple on the output of the phase detector. Since this ripple frequency is near the maximum cutoff frequency of the phase locked loop (700 cps), any phase shift due to the ripple filter, that is appreciable and occurs within the bandwidth of the loop, may result in loop instability and a reduction in the capture range. The oscillator circuit used in the present 500 cps synthesizer is a voltage controlled unit that has a reactance modulator gain variation of about 3 to 1 over the lock range of the loop. Therefore, the loop bandwidth and stability vary with the operating point of the locking voltage. Since the phase detector ripple voltage in the 100 cps synthesizer will be very near the cutoff frequency of the loop, the tuning characteristics of the reactance modulator will be changed to provide a more linear characteristic over the operating range. This variation in gain over the operating point for the 500 cps synthesizer did not have any detrimental effect, since the phase shift due to the various networks within the loop was well beyond the cutoff frequency of the loop. In the 500 cps synthesizer, due to the gain and phase relationships of the various circuits, the capture range was approximately equal to the locking range. In the 100 cps synthesizer the attainment of a linear reactance modulator characteristic will result in a reduction in the loop bandwidth while still retaining about the same

overall locking range. Along with this, in order to achieve a capture range that is nearly equal to the locking range, somewhat more elaborate phase detector and filter circuitry will be required. The characteristics of this circuitry will be such as to reduce the 1 kc ripple to low level while providing a response with negligible phase shift within the bandwidth of the loop. These requirements for the phase locked loop of the 100 cps synthesizer have resulted in an increased size for the oscillator subassembly previously mentioned.

4. STATEMENT OF WORK

The following work is to be performed on one R-1051 Receiver and one T-827 Transmitter:

1. Modify front panel VERNIER/CPS switch on R-1051 and T-827 units to provide 11 discrete positions as such:
 - 1 Vernier
 - 2-11 Locked position "000" to "900" in 100 cps increments
 - 3 Retain Existing Vernier Potentiometer
 - 4 Replace 500 cps control board
2. Replace existing 500 cps synthesizer module with new 100 cps synthesizer module.
 - a. Retain 7.1 mixer board from existing 500 cps synthesizer for new module.
3. Modify existing spectrum generator module to provide additional requirements necessary in the 100 cps synthesizer.
4. Incorporate the above modifications in a GFE R-1051/URR Receiver and T-827/URT Transmitter and perform functional tests on the modified units to verify correct 100 cycle tuning operation.